

Voltage Regulator VRG8667/68

COBHAM

Dual 1A ULDO Adjustable Positive Voltage Regulators

Released Datasheet

Cobham.com/HiRel

December 21, 2016

The most important thing we build is trust

FEATURES

- ❑ Manufactured using  Space Qualified RH3080 die
- ❑ Radiation performance
 - ♦ Total dose: 100 krad(Si), Dose rate = 50 - 300 rad(Si)/s
 - ♦ ELDRS: 50 krad(Si), Dose rate \leq 0.01 rad(Si)/s
- ❑ Two-Independent voltage regulators
- ❑ Current Limit with Foldback
- ❑ Over-temperature protection
- ❑ Output voltage adjustable: 0V to 35V
- ❑ Outputs may be paralleled for higher current
- ❑ Post Radiated Dropout voltage:
 - ♦ 0.60V @ 0.9Amps
 - ♦ 0.39V @ 0.5Amps
- ❑ Output current: 1.0Amps
- ❑ Packaging – Hermetic Meter Power Package
 - ♦ Thru-hole or Surface mount
 - ♦ 8 Leads, .755"L x .415"W x .220"Ht
 - ♦ Weight - 6 gm max
- ❑ Designed for aerospace and high reliability space applications
- ❑ **Radiation Hardness Assurance Plan: DLA Certified to MIL-PRF-38534, Appendix G.**

DESCRIPTION

The VRG8667/8668 consists of two Positive Adjustable (RH3080) ULDO voltage regulators each capable of supplying 1.0Amps over the output voltage range as defined under recommended operating conditions. The VRG8667/8668 offers excellent line and load regulation specifications and ripple rejection. There is full electrical isolation between the regulators and each regulator to the package.

The VRG8667/8668 has been specifically designed to meet exposure to radiation environments. The VRG8667 is configured for a Thru-Hole 8 lead metal power package and the VRG8668 is configured for a Surface Mount 8 lead metal power package. It is guaranteed operational from -55°C to +125°C. Available screened in accordance with MIL-PRF-38534, the VRG8667/8668 is ideal for demanding military and space applications.

Dropout ($V_{IN} - V_{OUT}$) decreases at lower load currents for both regulators.

Input capacitance is required for load regulation. 1 μ F is recommended on V_{in} and $V_{control}$. For stable operation, a 0.1 μ F capacitor should be placed on V_{set} and a low ESR capacitor on V_{out} . See Figure 5.

For detailed performance characteristic curves, applications information and typical applications see the latest  Linear Technology Corporation® data sheets for their RH/LT3080, which is available on-line at www.linear.com.

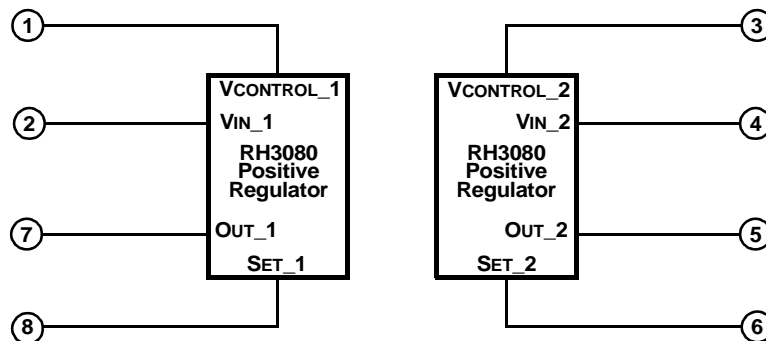

FIGURE 1 – BLOCK DIAGRAM / SCHEMATIC

ABSOLUTE MAXIMUM RATINGS

Parameter	Rating	Units
Input Voltage, V _{CONTROL} (Voltages are Relative to V _{OUT})	+40, -0.3	VDC
Output Current	1.2	A
Lead temperature (soldering 10 Sec)	300	°C
Input Output Differential	26	VDC
Output Voltage	36	VDC
ESD <u>1/</u>	2,000 - 3,999	V
Operating Junction Temperature Range	-55 to +150	°C
Storage Temperature Range	-65 to +150	°C
Thermal Resistance (Junction to Case) Θ_{Jc}	7	°C/W

1/ Meets ESD testing per MIL-STD-883, method 3015, Class 2.

NOTICE: Stresses above those listed under "Absolute Maximum Ratings" may cause permanent damage to the device. These are stress rating only; functional operation beyond the "Operation Conditions" is not recommended and extended exposure beyond the "Operation Conditions" may effect device reliability.

RECOMMENDED OPERATING CONDITIONS

Parameter	Range	Units
Output Voltage Range	0 to 35	VDC
Input Output Differential	0.5 to 26	VDC
Case Operating Temperature Range	-55 to +125	°C
Input Voltage (Voltages are Relative to V _{OUT})	1 to 36	V
V _{CONTROL} (Voltages are Relative to V _{OUT})	1.6 to 36	V

ELECTRICAL PERFORMANCE CHARACTERISTICS

Unless otherwise specified: $-55^{\circ}\text{C} \leq T_c \leq +125^{\circ}\text{C}$.

Parameter	Symbol	Conditions ($P \leq P_{MAX}$), <u>5/</u>	Min	Max	Units
Set Pin Current	I _{REF1}	$1.0\text{mA} \leq I_{LOAD} \leq 1.0\text{A}$, $V_{IN} = 1.6\text{V}$	9.80	10.35	μA
Set Pin Current <u>1/</u>	I _{REF2}	$V_{IN} = 1\text{V}$, $V_{CONTROL} = 2\text{V}$, $I_{LOAD} = 1\text{mA}$, $+25^{\circ}\text{C}$	9.80	10.40	
Output Offset Voltage (V _{OUT} - V _{SET})	V _{OS}	$V_{IN} = 1\text{V}$, $I_{LOAD} = 1\text{mA}$,	-6.0	6.0	mV
		$V_{IN} = 1\text{V}$, $I_{LOAD} = 1\text{mA}$, <u>1/</u> , $+25^{\circ}\text{C}$	-9.0	9.0	
Line Regulation	ΔV_{OS}	$1.6\text{V} \leq V_{IN} \leq 25\text{V}$, $V_{CONTROL} = 10\text{V}$, $I_{LOAD} = 1\text{mA}$	-0.07	0.07	mV/V
		$1\text{V} \leq V_{IN} \leq 26\text{V}$, $2\text{V} \leq V_{CONTROL} \leq 26\text{V}$, $I_{LOAD} = 1\text{mA}$, <u>1/</u> , <u>2/</u> , $+25^{\circ}\text{C}$	-0.15	0.15	
Load Regulation	ΔV_{OS}	$V_{IN} = 1.6\text{V}$, $I_{LOAD} = 1\text{mA}$ to 0.1A	-1	1	mV
		$I_{LOAD} = 1\text{mA}$ to 0.9A , <u>1/</u> , <u>2/</u> , $+25^{\circ}\text{C}$	-1.4	1.4	
V _{CONTROL} Dropout Voltage <u>2/</u>	V _{CDROP}	$V_{IN} = 0.6\text{V}$, $I_{LOAD} = 1.0\text{A}$, $+25^{\circ}\text{C}$, $+125^{\circ}\text{C}$	-	1.65	V
		$V_{IN} = 0.6\text{V}$, $I_{LOAD} = 0.9\text{A}$, -55°C	-	1.70	
		$V_{IN} = 1\text{V}$, $I_{LOAD} = 0.1\text{A}$ to 0.9A , <u>1/</u> , <u>4/</u> , $+25^{\circ}\text{C}$	-	1.60	
V _{IN} Dropout Voltage <u>2/</u>	V _{INDROP}	$I_{LOAD} = 1.0\text{A}$, $V_{CONTROL} = 2\text{V}$, $+25^{\circ}\text{C}$, $+125^{\circ}\text{C}$	-	0.5	V
		$I_{LOAD} = 0.8\text{A}$, $V_{CONTROL} = 2\text{V}$, -55°C	-	0.6	
		$I_{LOAD} = 0.1\text{A}$, $V_{CONTROL} = 2\text{V}$, <u>1/</u> , <u>4/</u> , $+25^{\circ}\text{C}$	-	0.25	
		$I_{LOAD} = 0.8\text{A}$, $V_{CONTROL} = 2\text{V}$, <u>1/</u> , <u>4/</u> , $+25^{\circ}\text{C}$	-	0.55	
Current Limit <u>3/</u>	I _{MAX}	$V_{IN} = V_{CONTROL} = +5\text{V}$, $V_{OUT} = 1.0\text{V}$, $+25^{\circ}\text{C}$	1.1	-	A
Minimum Load Current, <u>4/</u>	I _{MIN}	$V_{IN} = V_{CONTROL} = 26\text{V}$, $+125^{\circ}\text{C}$, -55°C	-	1	mA
		$V_{IN} = V_{CONTROL} = 26\text{V}$, <u>1/</u> , $+25^{\circ}\text{C}$	-	0.9	

ELECTRICAL PERFORMANCE CHARACTERISTICS

Unless otherwise specified: $-55^{\circ}\text{C} \leq T_c \leq +125^{\circ}\text{C}$.

Parameter	Symbol	Conditions ($P \leq P_{MAX}$), 5/	Min	Max	Units		
Ripple Rejection	-	$I_{LOAD} = 0.2\text{A}$, $V_{IN} = 3\text{V}$, $f = 120\text{Hz}$, $C_{OUT} = 2.2\mu\text{F}$, $C_{SET} = 0.1\mu\text{F}$	60	-	dB		
Thermal Regulation	-	30ms pulse		+25°C	-	0.03	%/W

Notes:

1/ Specification derated to reflect Total Dose exposure to 100 krad(Si) @+25°C.

2/ Dropout results from either minimum control voltage, $V_{CONTROL}$, or minimum input voltage, V_{IN} , both specified with respect to V_{OUT} . These specifications represent the minimum input-to-output differential voltage required to maintain regulation.

3/ Pulsed @ <10% duty cycle @ +25°C for characterization only. (See note 1/).

4/ Not production tested. Shall be guaranteed to the specified limits.

5/ V_{in} and $V_{control}$ are referenced to V_{out} unless otherwise stated.

VRG8667

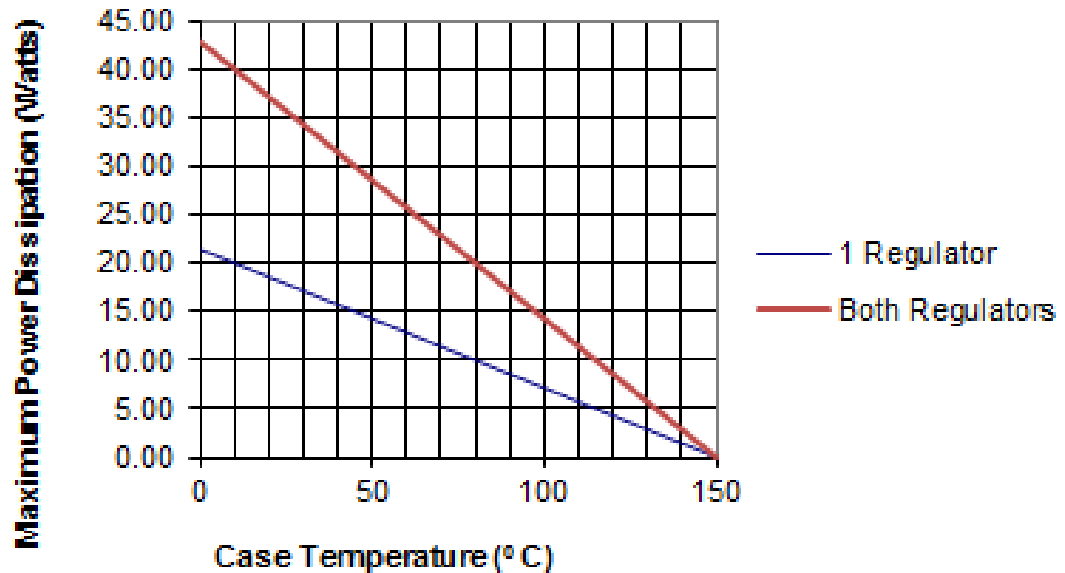

The maximum Power dissipation is limited by the thermal shutdown function of each regulator chip in the VRG8667/8668. The graph above represents the achievable power before the chip shuts down. The first line in the graph represents the maximum power dissipation of the VRG8667/8668 with one regulator on (the other off) and the other line represents both regulators on, dissipating equal power. If both regulators are on and one regulator is dissipating more power than the other, the maximum power dissipating of the VRG8667/8668 will fall between the two lines. This graph is based on the maximum junction temperature of 150°C and a thermal resistance (θ_{JC}) of 7°C/W.

FIGURE 2 – MAXIMUM POWER vs CASE TEMPERATURE

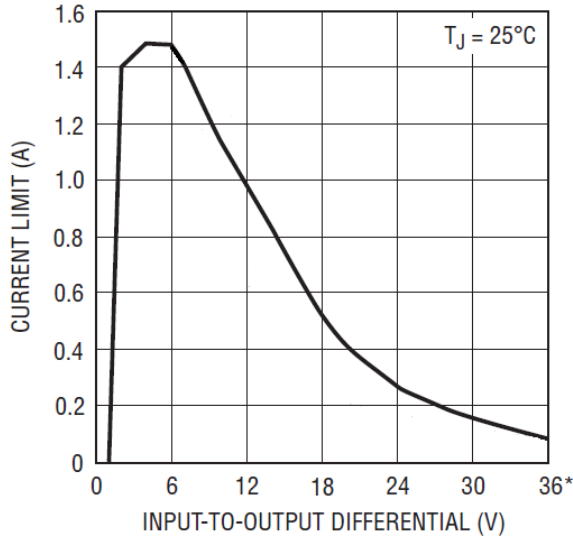

FIGURE 3 – RH3080 CURRENT LIMIT

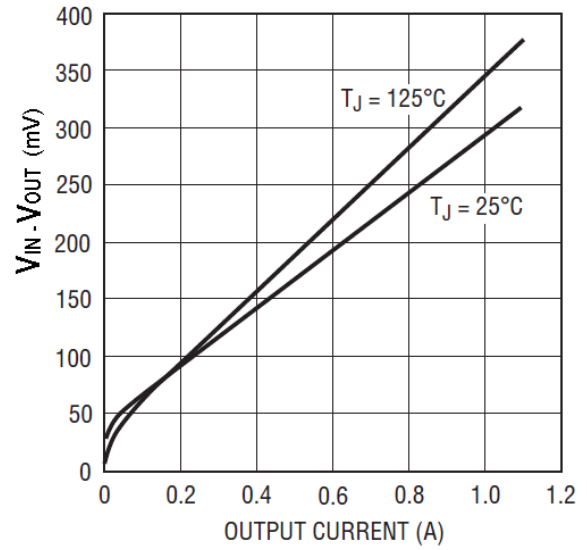
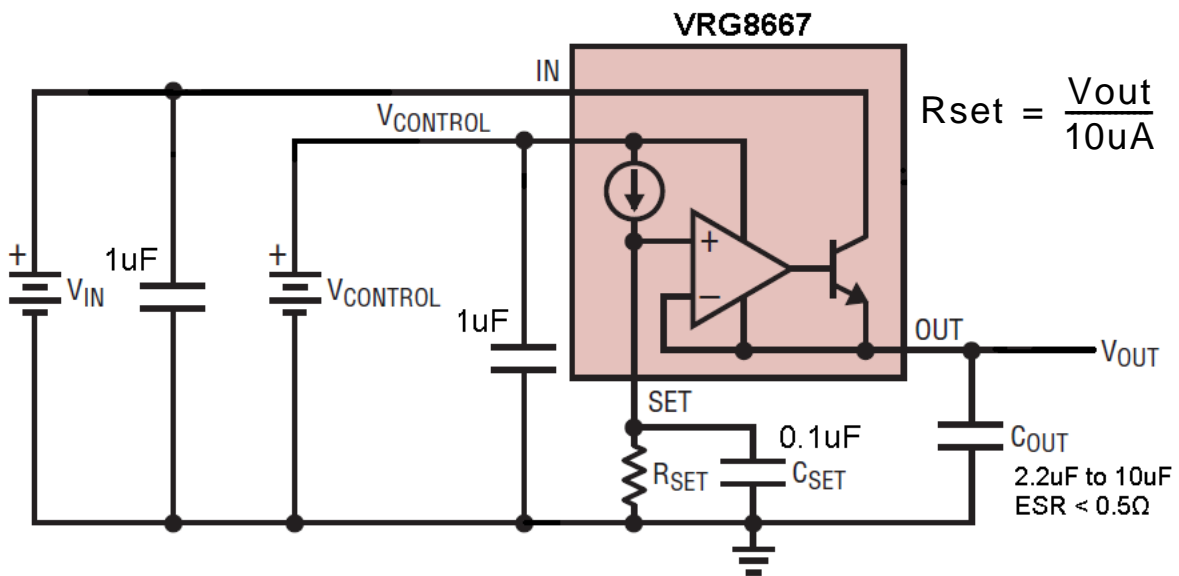

FIGURE 4 – RH3080 TYPICAL DROPOUT VOLTAGE CURVE (V_{CONTROL} ≥ 1.6V)



Note: All Capacitors are required for stable operation

FIGURE 5 – BASIC VRG8667 ADJUSTABLE REGULATOR APPLICATION

TABLE I – PIN NUMBERS vs FUNCTION

PIN	FUNCTION
1	VCONTROL_1
2	VIN_1
3	VCONTROL_2
4	VIN_2
5	OUT_2
6	SET_2
7	OUT_1
8	SET_1

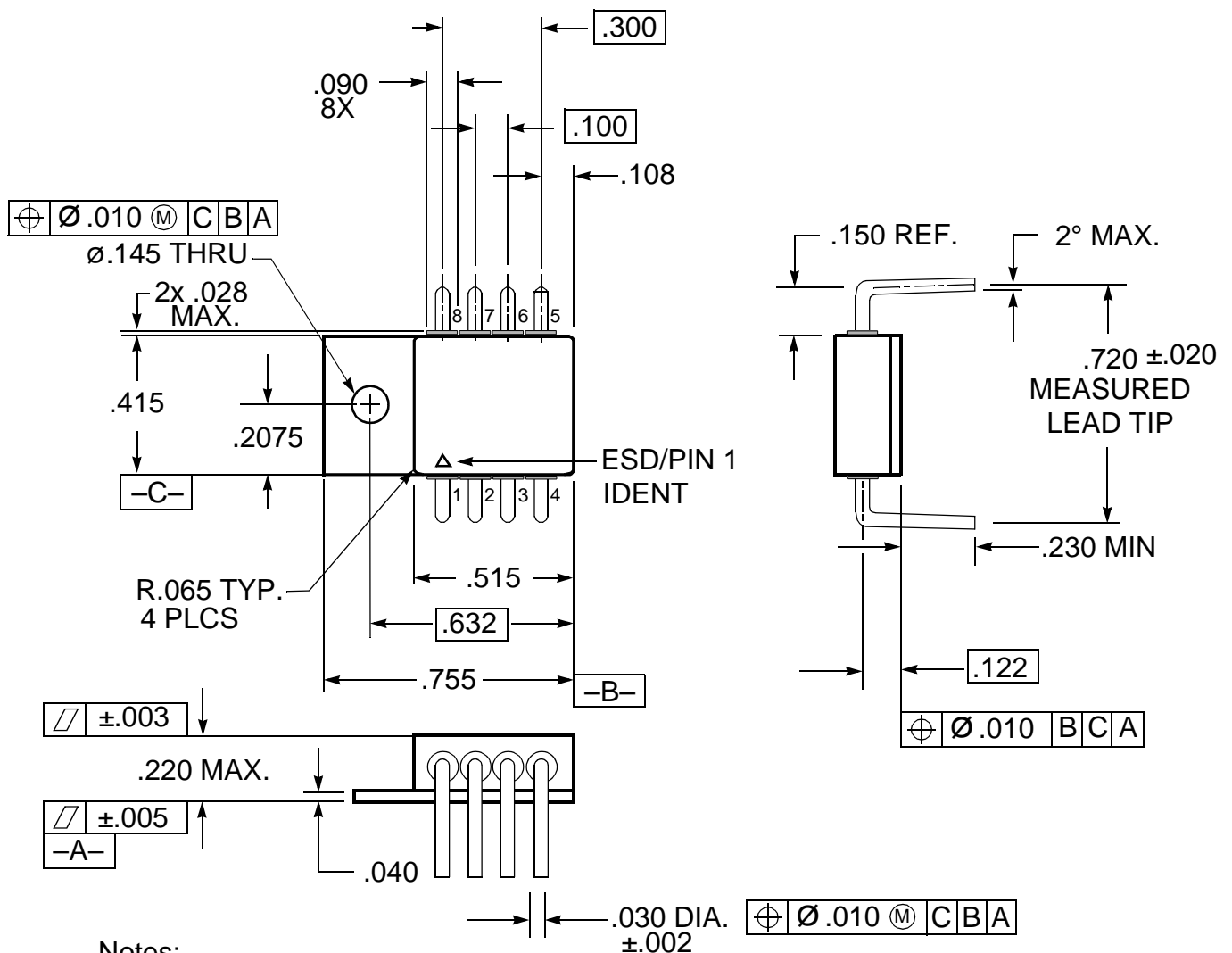

- Notes:
1. Dimension Tolerance: $\pm .005$ inches
 2. Package contains BeO substrate
 3. Case electrically isolated

FIGURE 6 – VRG8667 PACKAGE OUTLINE — THRU-HOLE POWER PACKAGE

TABLE II – PIN NUMBERS vs FUNCTION

PIN	FUNCTION
1	VCONTROL_1
2	VIN_1
3	VCONTROL_2
4	VIN_2
5	OUT_2
6	SET_2
7	OUT_1
8	SET_1

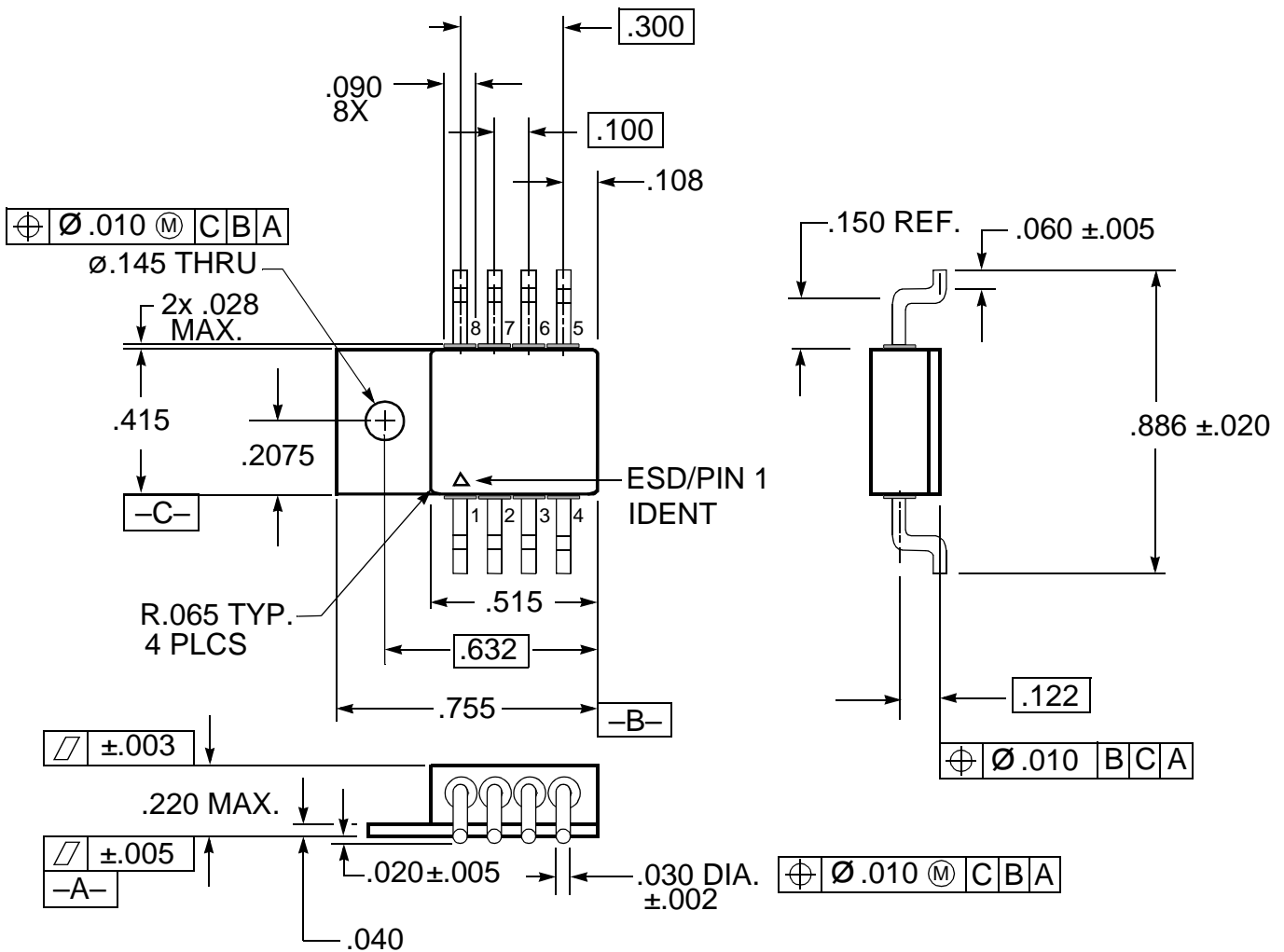

Notes:

1. Dimension Tolerance: $\pm .005$ inches
2. Package contains BeO substrate
3. Case electrically isolated

FIGURE 7 – VRG8668 PACKAGE OUTLINE — SURFACE MOUNT POWER PACKAGE

ORDERING INFORMATION

Model	DLA SMD #	Screening	Package
VRG8667-7	-	Commercial Flow, +25°C testing only	8-Lead Thru-Hole Power Pkg
VRG8667-901-1S	5962R1320301KUC	In accordance with DLA Certified RHA Program Plan to RHA Level "R", 100 krad(Si)	
VRG8667-901-2S	5962R1320301KUA		
VRG8668-7		Commercial Flow, +25°C testing only	8-Lead Surface-Mount Power Pkg
VRG8668-901-1S	5962R1320301KZC	In accordance with DLA Certified RHA Program Plan to RHA Level "R", 100 krad(Si)	
VRG8668-901-2S	5962R1320301KZA		

REVISION HISTORY

Date	Revision	Change Description
03/24/2016	E	Import into Cobham format
12/21/2016	F	a) Break out TID test limits from production temperature test limits. b) Unify testing conditions across documents. c) Modify note <u>2</u> /: Not production tested. d) Add note <u>4</u> /: Vin and Vcontrol are referenced to Vout.

Datasheet Definition

Advanced Datasheet - Product In Development

Preliminary Datasheet - Shipping Prototype

Datasheet - Shipping QML & Reduced Hi-Rel



For detailed performance characteristic curves, applications information and typical applications, see the latest  datasheet for their RH3080, which is available on-line at www.linear.com.

LT, LTC, Linear Technology and the Linear logo are registered trademarks and RH3080 is copyright Linear Technology Corporation.

EXPORT CONTROL:

This product is controlled for export under the Export Administration Regulations (EAR), 15 CFR Parts 730-774. A license from the Department of Commerce may be required prior to the export of this product from the United States.

Cobham Semiconductor Solutions
35 S. Service Road
Plainview, NY 11803

E: info-ams@cobham.com
T: 800 645 8862

COBHAM

Aeroflex Plainview Inc., DBA Cobham Semiconductor Solutions, reserves the right to make changes to any products and services described herein at any time without notice. Consult Aeroflex or an authorized sales representative to verify that the information in this data sheet is current before using this product. Aeroflex does not assume any responsibility or liability arising out of the application or use of any product or service described herein, except as expressly agreed to in writing by Aeroflex; nor does the purchase, lease, or use of a product or service from Aeroflex convey a license under any patent rights, copyrights, trademark rights, or any other of the intellectual rights of Aeroflex or of third parties.