

Voltage Regulator VRG8651/52

COBHAM

Dual LDO Adjustable Positive/Negative Voltage Regulators

Released Datasheet

Cobham.com/HiRel

October 6, 2016

The most important thing we build is trust

FEATURES

- ❑ Manufactured using  Space Qualified RH1086 and RH1185 die
- ❑ Radiation performance
 - Total dose ≥ 100 krad(Si),
Dose rate = 50-300 rad(Si)/s
- ❑ Two-Independent voltage regulators
- ❑ Thermal shutdown
- ❑ Adjustable Output Voltages
- ❑ **Positive** regulator features (RH1086)
 - Output voltage adjustable: 1.25V to 23V
 - Dropout voltage: 1.3V at 1.0 Amps
 - 3-Terminal
 - Output current: 1.0A, See note 13
 - Voltage reference: 1.25V +2%, -3.2%
 - Load regulation: 0.3% max
 - Line regulation: 0.25% max
 - Ripple rejection: >60dB
- ❑ **Negative** regulator features (RH1185)
 - Output voltage adjustable: -2.37 to -25V
 - Dropout voltage: 1.05V at 3Amps
 - 5-Terminal
 - Output current: 3A
 - Voltage reference: -2.370V $\pm 3\%$
 - Load regulation: 0.8% max
 - Line regulation: 0.02% max
 - Ripple rejection: >60dB
- ❑ **Packaging** – Hermetic metal
 - Thru-hole or Surface mount
 - 8 Leads, .755"L x .415"W x .200"Ht
 - Power package
 - Weight - 6 gm max
- ❑ Designed for aerospace and high reliability space applications

❑ **Radiation Hardness Assurance Plan: DLA Certified to MIL-PRF-38534, Appendix G.**

DESCRIPTION

The VRG8651/8652 consists of one Positive Adjustable (RH1086) and one Negative Adjustable (RH1185) LDO voltage regulator capable of supplying 1.0Amps (RH1086)/3Amps (RH1185) respectively over the output voltage range as defined under recommended operating conditions. The VRG8651/8652 offers excellent line and load regulation specifications and ripple rejection. There is full electrical isolation between the regulators and each regulator to the package.

The VRG8651/8652 serves a wide variety of applications including SCSI-2 Active Terminator, High Efficiency Linear Regulators, Post Regulators for Switching Supplies, Constant Current Regulators, Battery Chargers and Microprocessor Supply.

The VRG8651/8652 has been specifically designed to meet exposure to radiation environments. The VRG8651 is configured for a Thru-Hole 8 lead metal power package and the VRG8652 is configured for a Surface Mount 8 lead metal power package. It is guaranteed operational from -55°C to +125°C. Available screened to MIL-STD-883, the VRG8651/8652 is ideal for demanding military and space applications.

Dropout ($V_{IN} - V_{OUT}$) decreases at lower load currents for both regulators.

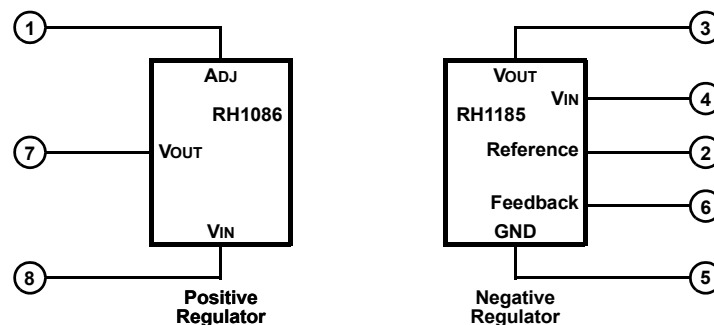

FIGURE 1 – BLOCK DIAGRAM / SCHEMATIC

ABSOLUTE MAXIMUM RATINGS

PARAMETER	RANGE		UNITS
	RH1086	RH1185	
Input Voltage	25+V _{REF}	-35	V _{DC}
Lead temperature (soldering 10 Sec)	300		°C
Input Output Differential	25	30	V _{DC}
Feedback & Reference Voltage	-	-7	V _{DC}
Output Voltage	+25	-30	V _{DC}
DC Output Current	1.5	-	A
ESD	2000 ^{1/}		V
Operating Junction Temperature Range	-55 to +150		°C
Storage Temperature Range	-65 to +150		°C

^{1/} Meets ESD testing per MIL-STD-883, method 3015, Class 1C.

NOTICE: Stresses above those listed under "Absolute Maximums Rating" may cause permanent damage to the device. These are stress rating only; functional operation beyond the "Operation Conditions" is not recommended and extended exposure beyond the "Operation Conditions" may effect device reliability.

RECOMMENDED OPERATING CONDITIONS

PARAMETER	RANGE		UNITS
	RH1086	RH1185	
Output Voltage Range	1.275 to 23	-2.45 to -25	V _{DC}
Input Output Differential	1.5 to 25	1 to 28	V _{DC}
Case Operating Temperature Range	-55 to +125		°C
Thermal Resistance, Junction to case θ_{jc}	5		°C/W

ELECTRICAL PERFORMANCE CHARACTERISTICS

Unless otherwise specified, these specifications apply for post radiation and $-55^{\circ}\text{C} \leq T_c \leq +125^{\circ}\text{C}$.

PARAMETER	SYM	CONDITIONS ($P \leq P_{MAX}$)	MIN	MAX	UNITS
RH1086 Positive LDO section only					
Reference Voltage ^{2/ 3/}	V _{REF}	$1.5V \leq V_{IN} - V_{OUT} \leq 15V$, I _{LOAD} = 10mA	1.210	1.275	V
Line Regulation ^{2/ 3/}	$\frac{\Delta V_{OUT}}{\Delta V_{IN}}$	I _{LOAD} = 10mA, $1.5V \leq V_{IN} - V_{OUT} \leq 15V$	-	0.25	%
Load Regulation ^{2/ 3/}	$\frac{\Delta V_{OUT}}{\Delta I_{OUT}}$	$10mA \leq I_{OUT} \leq 1.0A$, $V_{IN} - V_{OUT} = 3V$	-	0.3	%
Dropout Voltage ^{2/ 4/}	V _{DROP}	$\Delta V_{REF} = 1\%$, I _{OUT} = 1.0A	-	1.30	V
Adjust Pin Current ^{2/}	-		-	120	μA
Adjust Pin Current Change ^{2/}	-	$10mA \leq I_{OUT} \leq 1.0A$, $1.5V \leq V_{IN} - V_{OUT} \leq 15V$	-	5	μA
Current Limit ^{2/ 14/}	I _{MAX}	$V_{IN} - V_{OUT} = 5V$ $V_{IN} - V_{OUT} \leq 25V$	1.5 0.047	- -	A A
Minimum Load Current ^{5/}	I _{MIN}	$V_{IN} - V_{OUT} = 25V$	-	10	mA
Ripple Rejection ^{3/}	-	I _{OUT} = 1.0A, $V_{IN} - V_{OUT} = 3V$, f = 120Hz, C _{ADJ} = C _{OUT} = 25μF	60	-	dB
Thermal Regulation		30ms pulse, T _C = +25°C	-	0.04	%/W
V _{REF} Long-Term Stability ^{5/}		Burn In: T _C = +125°C @ 1000hrs min, tested @ 25°C	-	0.3	%

ELECTRICAL PERFORMANCE CHARACTERISTICS

Unless otherwise specified, these specifications apply for post radiation and $-55^{\circ}\text{C} \leq T_c \leq +125^{\circ}\text{C}$.

PARAMETER	SYM	CONDITIONS ($P \leq P_{MAX}$)	MIN	MAX	UNITS
RH1185 Negative LDO section only <u>1/</u>, <u>9/</u>					
Reference Voltage (At pin 6) <u>2/</u> <u>9/</u>	V _{REF}	$1\text{mA} \leq I_{OUT} \leq 3\text{A}$, $V_{IN} - V_{OUT} = 1.2\text{V to } 28\text{V}$, $V_{OUT} = -5\text{V}$	-2.29	-2.45	V
Dropout Voltage <u>2/</u> <u>6/</u>	V _{DROP}	$I_{OUT} = 0.5\text{A}$, $V_{OUT} = -5\text{V}$	-	0.425	V
		$I_{OUT} = 3\text{A}$, $V_{OUT} = -5\text{V}$	-	1.05	V
Line Regulation <u>2/</u> <u>10/</u>	$\frac{\Delta V_{OUT}}{\Delta V_{IN}}$	$1.0\text{V} \leq V_{IN} - V_{OUT} \leq 20\text{V}$, $V_{OUT} = -5\text{V}$	-	0.02	%/V
Load Regulation <u>2/</u> <u>10/</u>	$\frac{\Delta V_{OUT}}{\Delta I_{OUT}}$	$5\text{mA} \leq I_{OUT} \leq 3\text{A}$, $V_{IN} - V_{OUT} = 1.5\text{V to } 10\text{V}$, $V_{OUT} = -5\text{V}$	-	0.8	%
Minimum Input Voltage <u>2/</u> <u>7/</u>	V _{IN MIN}	$I_{OUT} = 3\text{A}$, $V_{OUT} = V_{REF}$	-	-4.50	V
Internal Current Limit (See Graph for Guaranteed Curve - See Figure 6) <u>2/</u> <u>14/</u>	I _{CL}	$1.5\text{V} \leq V_{IN} - V_{OUT} \leq 10\text{V}$	3.3	4.55	A
		$V_{IN} - V_{OUT} = 15\text{V}$	2.0	4.5	A
		$V_{IN} - V_{OUT} = 20\text{V}$	1.0	3.1	A
		$V_{IN} - V_{OUT} = 30\text{V}$ <u>5/</u>	0.2	1.6	A
External Current Limit <u>2/</u>	I _{LIM}	$R_{LIM} = 5\text{K}\Omega$ <u>12/</u>	2.7	3.7	A
		$R_{LIM} = 15\text{K}\Omega$ <u>12/</u>	0.9	1.6	A
Quiescent Supply Current <u>2/</u> <u>8/</u>	I _Q	$I_{OUT} = 5\text{mA}$, $V_{OUT} = V_{REF}$, $-4\text{V} \leq V_{IN} \leq -25\text{V}$	-	3.5	mA
Supply Current Change with Load <u>2/</u>	I _{QΔ}	$V_{IN} - V_{OUT} = V_{SAT}$ <u>11/</u>	-	35	mA/A
		$V_{IN} - V_{OUT} \geq 2\text{V}$	-	21	mA/A
Ripple Rejection	-	$I_{OUT} = 1.0\text{A}$, $V_{IN} - V_{OUT} = 3\text{V}$, $f = 120\text{Hz}$,	60	-	dB
Thermal Regulation (See application information LT1185) <u>5/</u>	-	$V_{IN} - V_{OUT} = 10\text{V}$, $I_{OUT} = 5\text{mA to } 2\text{A}$, $T_c = +25^{\circ}\text{C}$	-	0.014	%/W

Notes

- Meets ESD testing per MIL-STD-883, method 3015, Class 2.
- Specification derated to reflect High Dose Rate (1019 condition A) to 100 krad(Si) @ +25°C.
- Line and load regulation are guaranteed up to the maximum power dissipation of 15W. Power dissipation is determined by the input/output differential voltage and the output current. Guaranteed maximum power dissipation will not be available over the full input/output voltage range.
- Dropout voltage is specified over the full output current range of the device.
- Not tested. Shall be guaranteed by design, characterization, or correlation to other tested parameters.
- Dropout voltage is tested by reducing input voltage until the output drops 1% below its nominal value. Tests are done at 0.5A and 3A. The power transistor looks basically like a pure resistance in this range so that minimum differential at any intermediate current can be calculated by interpolation; $V_{DROPOUT} = 0.25\text{V} + (0.25\Omega \times I_{OUT})$. For load current less than 0.5A, see Figure 4.
- "Minimum input voltage" is limited by base emitter voltage drive of the power transistor section, not saturation as measured in Note 6. For output voltages below 4V, "minimum input voltage" specification may limit dropout voltage before transistor saturation limitation.
- Supply current is measured on the ground pin, and does not include load current, R_{LIM}, or output divider current.
- The 25W power level is guaranteed for an input-output voltage of 8.3V to 17V. At lower voltages the 3A limit applies, and at higher voltages the internal power limiting may restrict regulator power below 25W.
- Line and load regulation are measured on a pulse basis with a pulse width of 2ms, to minimize heating. DC regulation will be affected by thermal regulation and temperature coefficient of the reference.
- V_{SAT} is the maximum specified dropout voltage; $0.25\text{V} + (0.25\Omega \times I_{OUT})$.
- Current limit is programmed with a resistor from REF pin to GND pin. $R_{LIM} = 15\text{K}\Omega/I_{LIM}$.
- For compliance with MIL-STD- 883 revision C current density specification, the RH1086MK is derated to 1 Amp but is capable of 1.5 Amps.
- Pulsed @ <10% duty cycle @ +25°C.

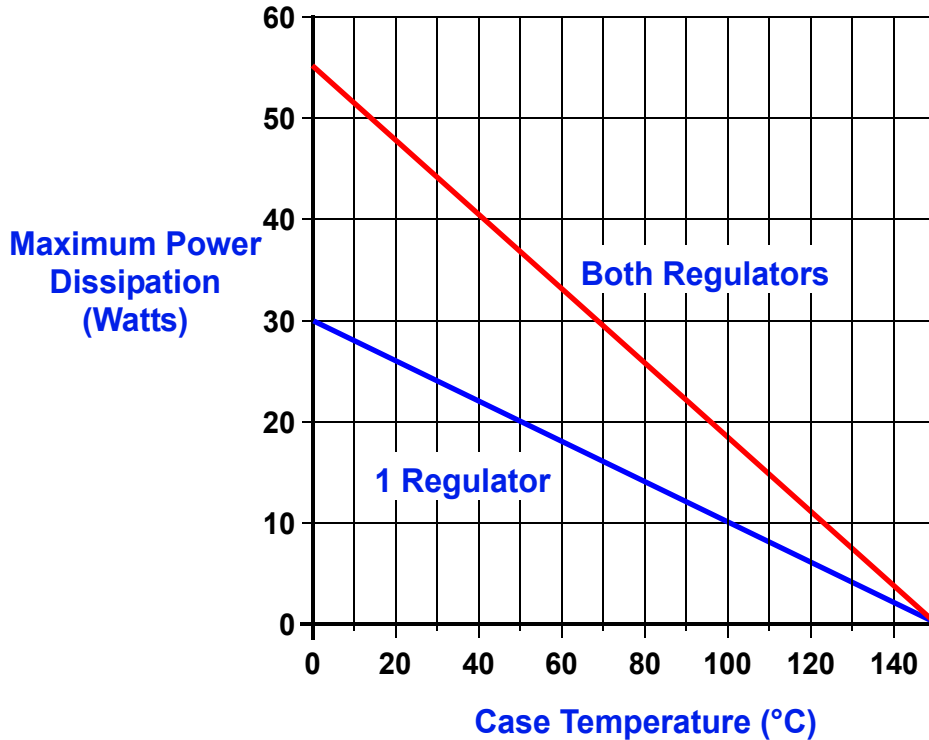

FIGURE 2 – MAXIMUM POWER vs CASE TEMPERATURE

The maximum Power dissipation is limited by the thermal shutdown function of each regulator chip in the VRG8651/8652. The graph above represents the achievable power before the chip shuts down. The first line in the graph represents the maximum power dissipation of the VRG8651/8652 with one regulator on (the other off) and the other line represents both regulators on dissipating equal power. If both regulators are on and one regulator is dissipating more power than the other, the maximum power dissipation of the VRG8651/8652 will fall between the two lines. This graph is based on the maximum junction temperature of 150°C and a thermal resistance (θ_{JC}) of 5°C/W.

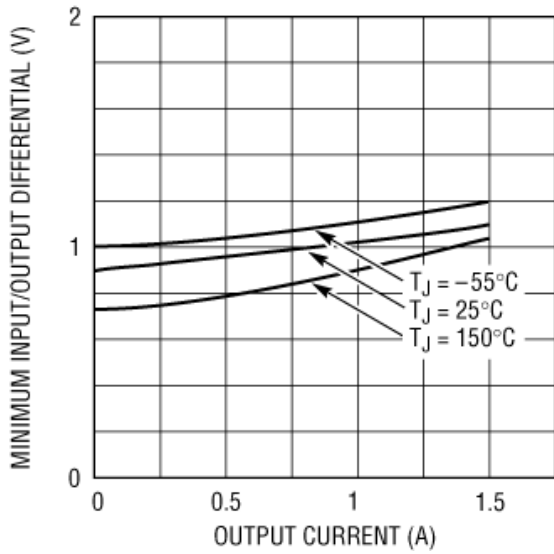

FIGURE 3 – RH1086 DROPOUT VOLTAGE TYPICAL CURVE

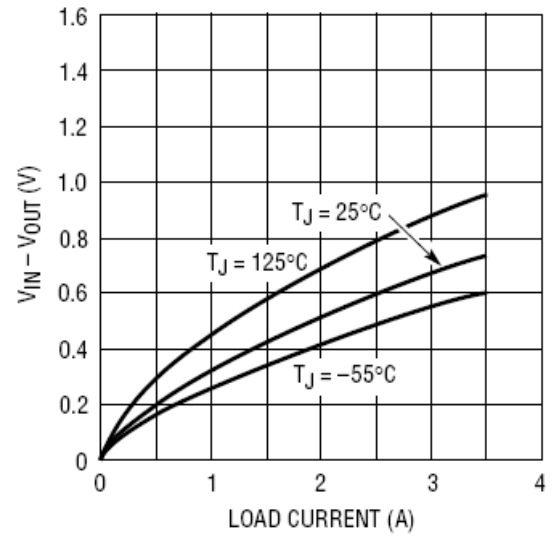

FIGURE 4 – RH1185 DROPOUT VOLTAGE TYPICAL CURVE

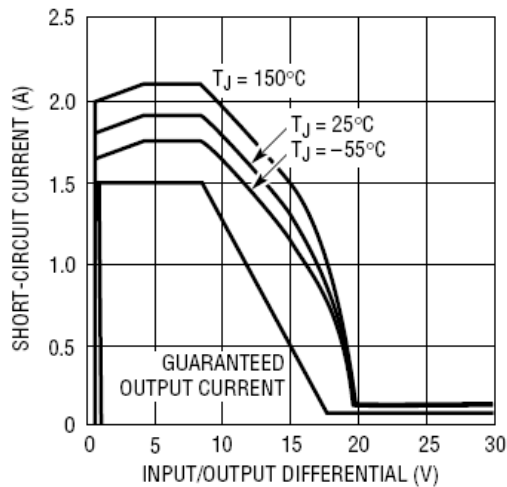

FIGURE 5 – RH1086 SHORT CIRCUIT CURRENT

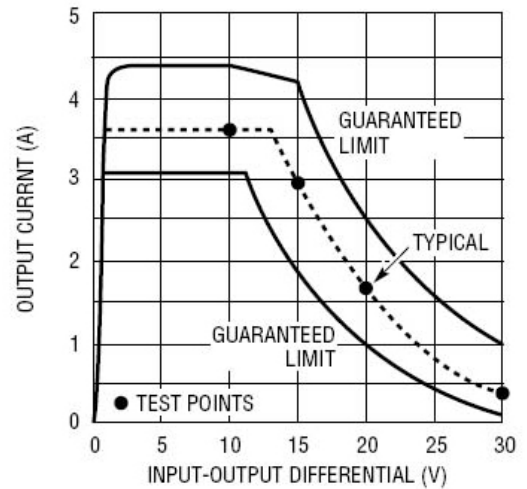

FIGURE 6 – RH1185 INTERNAL CURRENT LIMIT

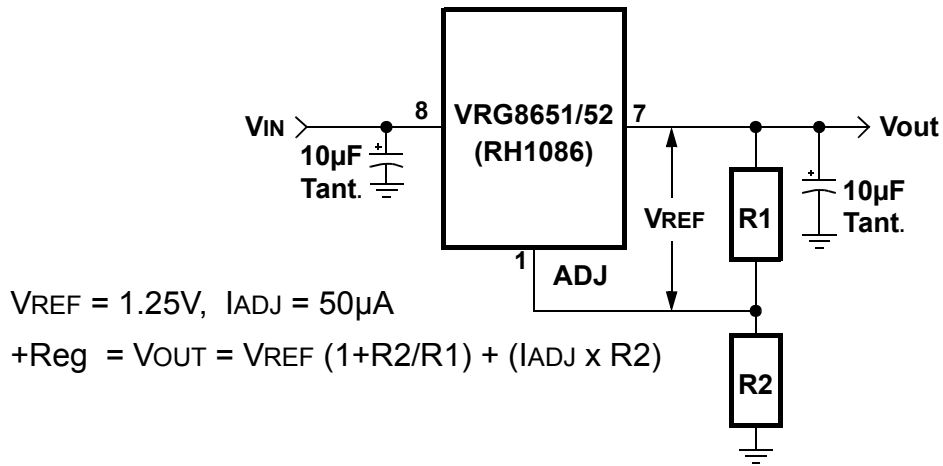

FIGURE 7 – BASIC RH1086 ADJUSTABLE REGULATOR APPLICATION

The RH1185 output voltage is set by two external resistors. Internal reference voltage is trimmed to 2.37V so that a standard 1% 2.37k resistor (R1) can be used to set divider current at 1mA. R2 is then selected from:

$$R2 = \frac{(V_{OUT} - 2.37) R1}{V_{REF}}$$

for R1 = 2.37k and VREF = 2.37V, this reduces to:

$$R2 = \frac{V_{OUT} - 2.37}{10^{-3}}$$

suggested values of 1% resistors are shown.

V _{OUT}	R2 WHEN R1 = 2.37k
2.5V	130Ω
3.3V	930Ω
5V	2.67k
12V	9.76k
15V	12.7k

SETTING OUTPUT VOLTAGE

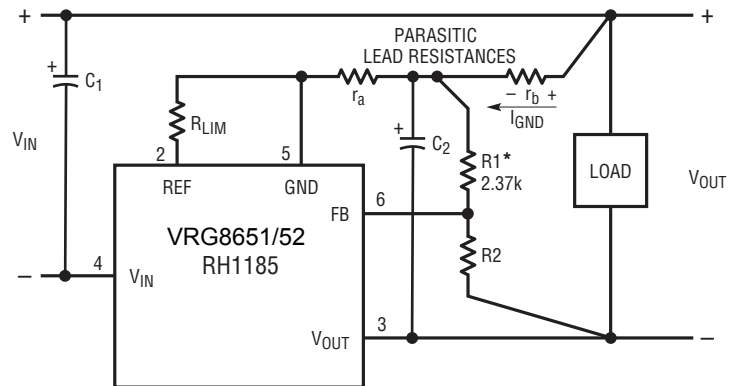

*R1 SHOULD BE CONNECTED DIRECTLY TO GROUND LEAD, NOT TO THE LOAD, SO THAT $r_a \approx 0\Omega$. THIS LIMITS THE OUTPUT VOLTAGE ERROR TO $(I_{GND})(r_b)$. ERRORS CREATED BY r_a ARE MULTIPLIED BY $(1 + R2/R1)$. NOTE THAT V_{OUT} INCREASES WITH INCREASING GROUND PIN CURRENT. R2 SHOULD BE CONNECTED DIRECTLY TO LOAD FOR REMOTE SENSING. $C1 = C2 \geq 2\mu F$ Tantalum.

R1 & R2 LOCATION & PROPER CONNECTION OF POSITIVE SENSE LEAD

FIGURE 8 – BASIC RH1185 ADJUSTABLE REGULATOR APPLICATION

TABLE I – PIN NUMBERS vs FUNCTION

PIN	FUNCTION
1	POS_ADJ_1
2	NEG_REF_2
3	NEG_VOUT_2
4	NEG_VIN_2
5	NEG_GND_2
6	NEG_FB_2
7	POS_VOUT_1
8	POS_VIN_1

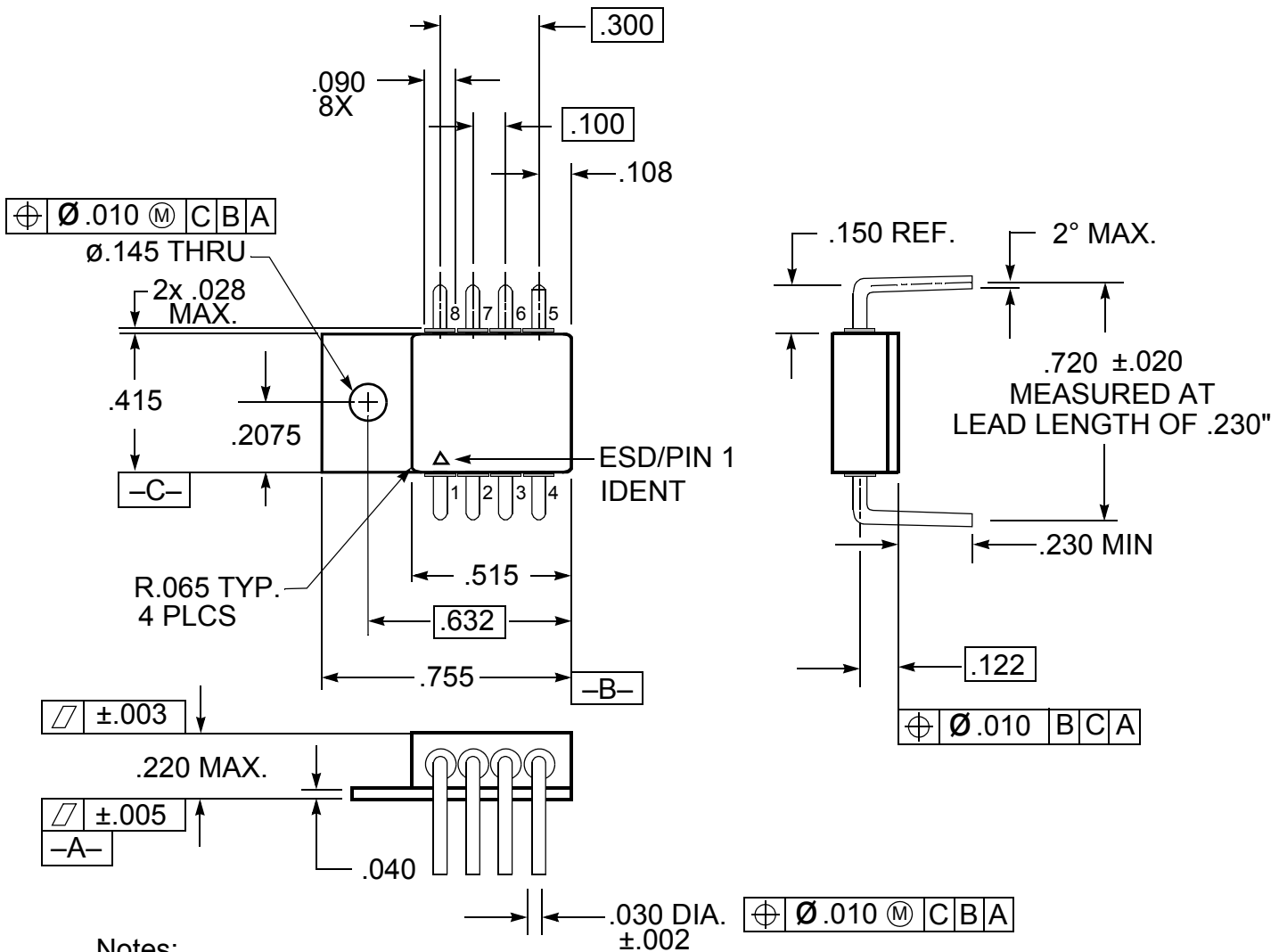

Notes:

1. Dimension Tolerance: $\pm .005$ inches
2. Package contains BeO substrate
3. Case electrically isolated

FIGURE 9 – PACKAGE OUTLINE — THRU-HOLE POWER PACKAGE

TABLE II – PIN NUMBERS vs FUNCTION

PIN	FUNCTION
1	POS_ADJ_1
2	NEG_REF_2
3	NEG_VOUT_2
4	NEG_VIN_2
5	NEG_GND_2
6	NEG_FB_2
7	POS_VOUT_1
8	POS_VIN_1

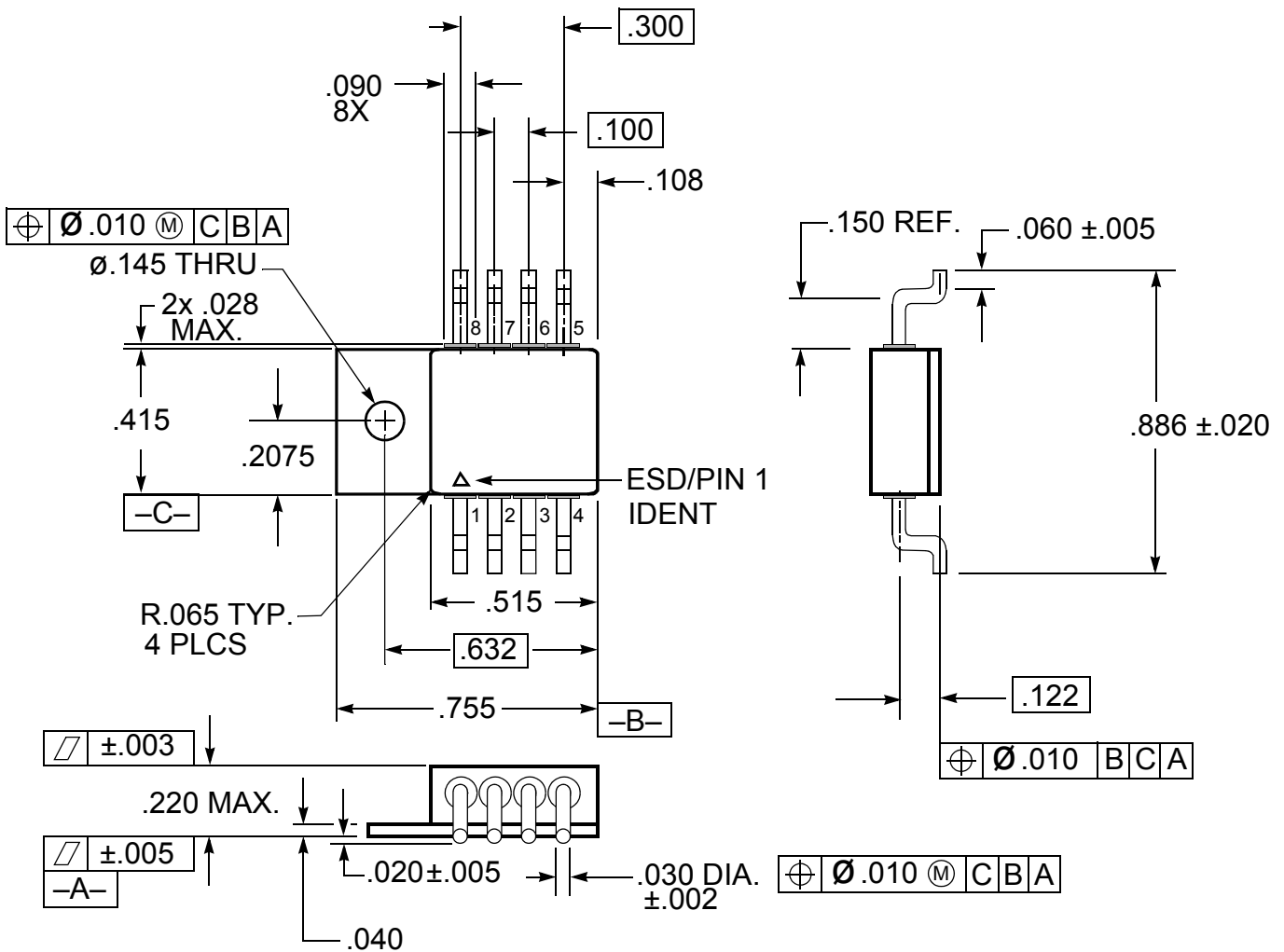

Notes:

1. Dimension Tolerance: $\pm .005$ inches
2. Package contains BeO substrate
3. Case electrically isolated

FIGURE 10 – PACKAGE OUTLINE — SURFACE MOUNT POWER PACKAGE

ORDERING INFORMATION

MODEL	DLA SMD #	SCREENING	PACKAGE
VRG8651-7	-	Commercial Flow, +25°C testing only	8 Lead Thru-Hole Power Pkg
VRG8651-S	-	Military Temperature, -55°C to +125°C Screened in accordance with the individual Test Methods of MIL-STD-883 for Space Applications	
VRG8651-201-1S	5962-0920101KUC	In accordance with DLA SMD	
VRG8651-201-2S	5962-0920101KUA		
VRG8651-901-1S	5962R0920101KUC	In accordance with DLA Certified RHA Program Plan to RHA Level "R", 100 krad(Si)	
VRG8651-901-2S	5962R0920101KUA		
VRG8652-7	-	Commercial Flow, +25°C testing only	8 Lead Surface Mount Power Pkg
VRG8652-S	-	Military Temperature, -55°C to +125°C Screened in accordance with the individual Test Methods of MIL-STD-883 for Space Applications	
VRG8652-201-1S	5962-0920101KZC	In accordance with DLA SMD	
VRG8652-201-2S	5962-0920101KZA		
VRG8652-901-1S	5962R0920101KZC	In accordance with DLA Certified RHA Program Plan to RHA Level "R", 100 krad(Si)	
VRG8652-901-2S	5962R0920101KZA		

REVISION HISTORY

Date	Revision	Change Description
03/24/2016	L	Import into Cobham format
10/6/2016	M	Correct Figure 8 pinouts

Datasheet Definition

Advanced Datasheet - Product In Development

Preliminary Datasheet - Shipping Prototype

Datasheet - Shipping QML & Reduced Hi-Rel



For detailed performance characteristic curves, applications information and typical applications, see the latest



datasheets for their RH1086 & RH1185, which are available on-line at www.linear.com.

LT, LTC, Linear Technology and the Linear logo are registered trademarks and RH1086 & RH1185 are copyright Linear Technology Corporation.

The following United States (U.S.) Department of Commerce statement shall be applicable if these commodities, technology, or software are exported from the U.S.: These commodities, technology, or software were exported from the United States in accordance with the Export Administration Regulations. Diversion contrary to U.S. law is prohibited.

Cobham Semiconductor Solutions
35 S. Service Road
Plainview, NY 11803

E: info-ams@cobham.com
T: 800 645 8862

COBHAM

Aeroflex Plainview Inc., DBA Cobham Semiconductor Solutions, reserves the right to make changes to any products and services described herein at any time without notice. Consult Aeroflex or an authorized sales representative to verify that the information in this data sheet is current before using this product. Aeroflex does not assume any responsibility or liability arising out of the application or use of any product or service described herein, except as expressly agreed to in writing by Aeroflex; nor does the purchase, lease, or use of a product or service from Aeroflex convey a license under any patent rights, copyrights, trademark rights, or any other of the intellectual rights of Aeroflex or of third parties.