

# Voltage Regulator VRG8609/10

Dual 1.5A Adjustable Negative Voltage Regulators

Released Datasheet

[Cobham.com/HiRel](http://Cobham.com/HiRel)

March 24, 2016

# COBHAM

The most important thing we build is trust

## FEATURES

- ❑ Manufactured using  Linear Technology Corporation ® Space Qualified RH137 die
  - ❑ Radiation performance
    - Total dose: 100 krad(Si),  
Dose rate = 50-300 rad(Si)/s
    - ELDRS: 50 krad(Si),  
Dose rate ≤ 10 mrad(Si)/S
  - ❑ Thermal shutdown
  - ❑ Output voltage adjustable: -1.25V to -27V
  - ❑ 3-Terminal
  - ❑ Output current: 1.5A
  - ❑ Voltage reference: -1.25V
  - ❑ Load regulation: 1.0% max
  - ❑ Line regulation: 0.05% max
  - ❑ Ripple rejection: >66dB
  - ❑ Packaging – Hermetic metal
    - Thru-hole or Surface mount
    - 6 Leads, .655"L x .415"W x .200"Ht
    - Power package
    - Weight - 5 gm max
  - ❑ Designed for aerospace and high reliability space applications
- ❑ **Radiation Hardness Assurance Plan: DLA Certified to MIL-PRF-38534, Appendix G.**

## DESCRIPTION

The VRG8609/10 consists of two negative (RH137) voltage regulators each capable of supplying in excess of 1.5Amps over the output voltage range as defined under recommended operating conditions. Each regulator is exceptionally easy to set-up, requiring only 2 external resistors to set the output voltage. The module design has been optimized for excellent regulation and low thermal transients. There is full electrical isolation between the regulators and each regulator to the package.

Further, the VRG8609/10 features internal current limiting, thermal shutdown and safe-area compensation, making them virtually blowout-proof against overloads. The VRG8609/10 serves a wide variety of applications including local on-card regulation, programmable output voltage regulation or precision current regulation.

The VRG8609/10 has been specifically designed to meet exposure to radiation environments. The VRG8609 is configured for a Thru-Hole 6 lead metal power package and the VRG8610 is configured for a Surface Mount 6 lead metal power package. It is guaranteed operational from -55°C to +125°C. Available screened to MIL-STD-883, the VRG8609/10 is ideal for demanding military and space applications.

For detailed performance characteristic curves, applications information and typical applications see the latest  Linear Technology Corporation ® data sheets for their RH/LT137, which is available on-line at [www.linear.com](http://www.linear.com).

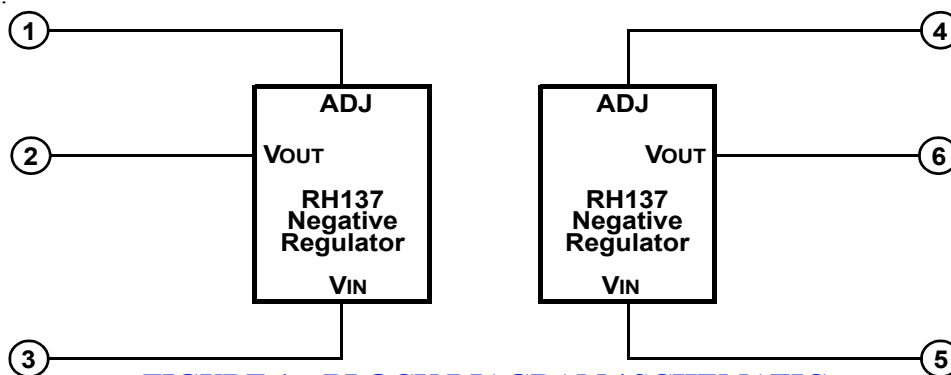

**FIGURE 1 – BLOCK DIAGRAM / SCHEMATIC**

## ABSOLUTE MAXIMUM RATINGS

PARAMETER	RANGE	UNITS
Operating (Junction) Temperature Range	-55 to +150	°C
Lead Temperature (soldering, 10 sec)	300	°C
Storage Temperature Range	-65 to +150	°C
Input-Output Voltage Differential	30 (Neg)	V
Thermal Resistance (junction to case $\Theta_{JC}$ ) each, Pos. & Neg.	5	°C/W
ESD Rating	1.999 <sup>1/</sup>	KV

<sup>1/</sup> Meets ESD testing per MIL-STD-883, method 3015, Class 1C.

NOTICE: Stresses above those listed under "Absolute Maximums Rating" may cause permanent damage to the device. These are stress rating only; functional operation beyond the "Operation Conditions" is not recommended and extended exposure beyond the "Operation Conditions" may effect device reliability.

## RECOMMENDED OPERATING CONDITIONS

PARAMETER	RANGE	UNITS
Output Voltage Range	-1.3 to -27	VDC
Case Operating Temperature Range	-55 to +125	°C

## ELECTRICAL PERFORMANCE CHARACTERISTICS <sup>1/</sup>

PARAMETER	SYM	CONDITIONS (P ≤ P <sub>MAX</sub> )	MIN	MAX	UNITS
Reference Voltage <sup>4/</sup>	V <sub>REF</sub>	3V ≤ (V <sub>IN</sub> - V <sub>OUT</sub> ) ≤ V <sub>DIFF MAX</sub> , 10mA ≤ I <sub>OUT</sub> ≤ I <sub>MAX</sub>	-1.200	-1.300	V
Line Regulation <sup>2/</sup> , <sup>4/</sup>	$\frac{\Delta V_{OUT}}{\Delta V_{IN}}$	3V ≤ (V <sub>IN</sub> - V <sub>OUT</sub> ) ≤ 30V,	-	0.05	%/V
Load Regulation <sup>2/</sup> , <sup>4/</sup>	$\frac{\Delta V_{OUT}}{\Delta I_{OUT}}$	10mA ≤ I <sub>OUT</sub> ≤ I <sub>MAX</sub> , V <sub>OUT</sub> ≤ 5V 10mA ≤ I <sub>OUT</sub> ≤ I <sub>MAX</sub> , V <sub>OUT</sub> ≥ 5V	-	50 1.0	mV %
Thermal Regulation		I <sub>OUT</sub> = 1.5A, (V <sub>IN</sub> - V <sub>OUT</sub> ) = 13.3V, 20ms Pulse, 20W, T <sub>C</sub> = +25°C	-	0.02	%/W
Ripple Rejection		V <sub>OUT</sub> = -10V, f = 120Hz, C <sub>ADJ</sub> = 10μF	66	-	dB
Adjustment Pin Current <sup>4/</sup>	I <sub>ADJ</sub>	I <sub>OUT</sub> = 10mA, 3V ≤ (V <sub>IN</sub> - V <sub>OUT</sub> ) ≤ 30V	-	100	μA
Adjustment Pin Current Change <sup>4/</sup>	ΔI <sub>ADJ</sub>	3V ≤ (V <sub>IN</sub> - V <sub>OUT</sub> ) ≤ 30V, 10mA ≤ I <sub>OUT</sub> ≤ I <sub>MAX</sub>	-	5	μA
Minimum Load Current <sup>3/</sup> <sup>4/</sup>	I <sub>MIN</sub>	(V <sub>IN</sub> - V <sub>OUT</sub> ) = 30V (V <sub>IN</sub> - V <sub>OUT</sub> ) ≤ 10V	-	5 3	mA
Current Limit <sup>4/</sup> , <sup>5/</sup>	I <sub>MAX</sub>	(V <sub>IN</sub> - V <sub>OUT</sub> ) ≤ 15V (V <sub>IN</sub> - V <sub>OUT</sub> ) = 30V, T <sub>C</sub> = +25°C	1.5 0.24	-	A
Long Term Stability <sup>3/</sup>	$\frac{\Delta V_{OUT}}{\Delta TIME}$	T <sub>C</sub> = +125°C	-	1	%
Thermal Resistance, each Regulator (Junction to Case) <sup>3/</sup>	Θ <sub>JC</sub>		-	5	°C/W

Notes:

<sup>1/</sup> Unless otherwise specified, these specifications apply for, (V<sub>IN</sub> - V<sub>OUT</sub>) = 5V, I<sub>out</sub> = 0.5A and -55°C < T<sub>c</sub> < +125°C.

<sup>2/</sup> Regulation is measured at a constant junction temperature, using pulse testing with a low duty cycle. Changes in output voltage due to heating effects are covered under the specification for thermal regulation. Measurements taken at the output lead must be adjusted for lead resistance.

<sup>3/</sup> Not tested. Shall be guaranteed to the specified limits.

<sup>4/</sup> Specification derated to reflect High Dose Rate (1019 condition A) to 100 krad(Si) and Low Dose Rate (1019 condition D) to 50 krad(Si), @ +25°C.

<sup>5/</sup> Pulsed @ < 10% duty cycle @ +25°C.

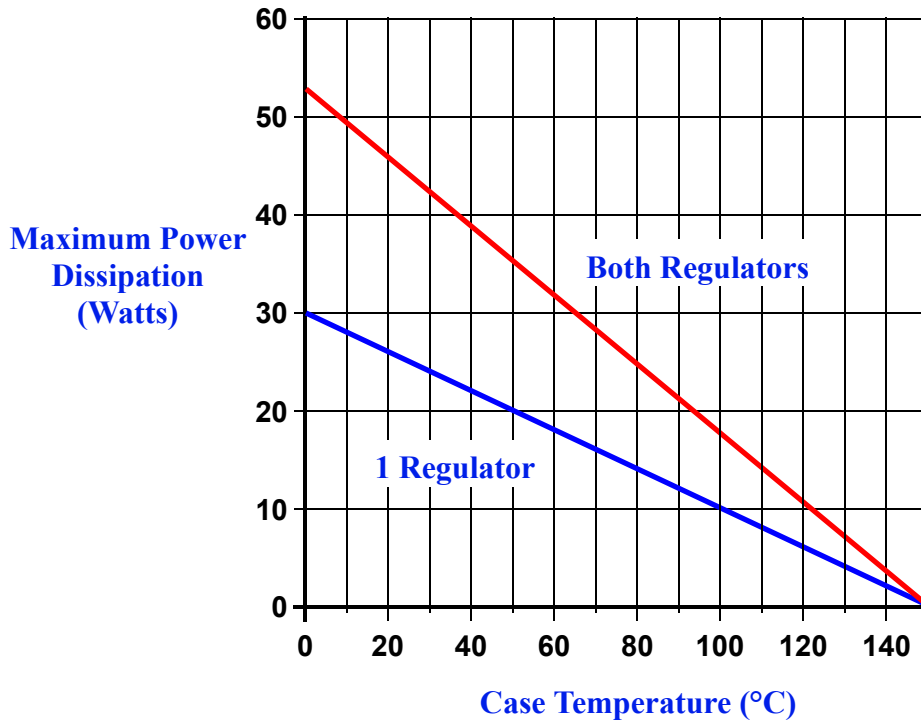

**FIGURE 2 – MAXIMUM POWER vs CASE TEMPERATURE**

The maximum Power dissipation is limited by the thermal shutdown function of each regulator chip in the VRG8609/10. The graph above represents the achievable power before the chip shuts down. The first line in the graph represents the maximum power dissipation of the VRG8609/10 with one regulator on (the other off) and the other line represents both regulators on dissipating equal power. If both regulators are on and one regulator is dissipating more power than the other, the maximum power dissipation of the VRG8609/10 will fall between the two lines. This graph is based on the maximum junction temperature of 150°C and a thermal resistance ( $\Theta_{JC}$ ) of 5°C/W.

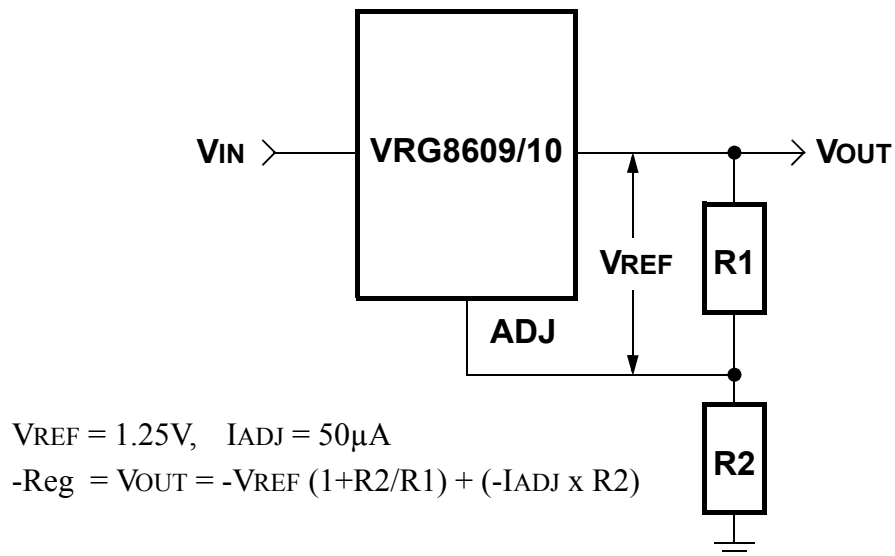

**Adjustable Regulator**  
**FIGURE 3 – TYPICAL APPLICATIONS**

**TABLE I – PIN NUMBERS vs FUNCTION**

PIN	FUNCTION
1	NEG_ADJ_1
2	NEG_VOUT_1
3	NEG_VIN_1
4	NEG_ADJ_2
5	NEG_VIN_2
6	NEG_VOUT_2

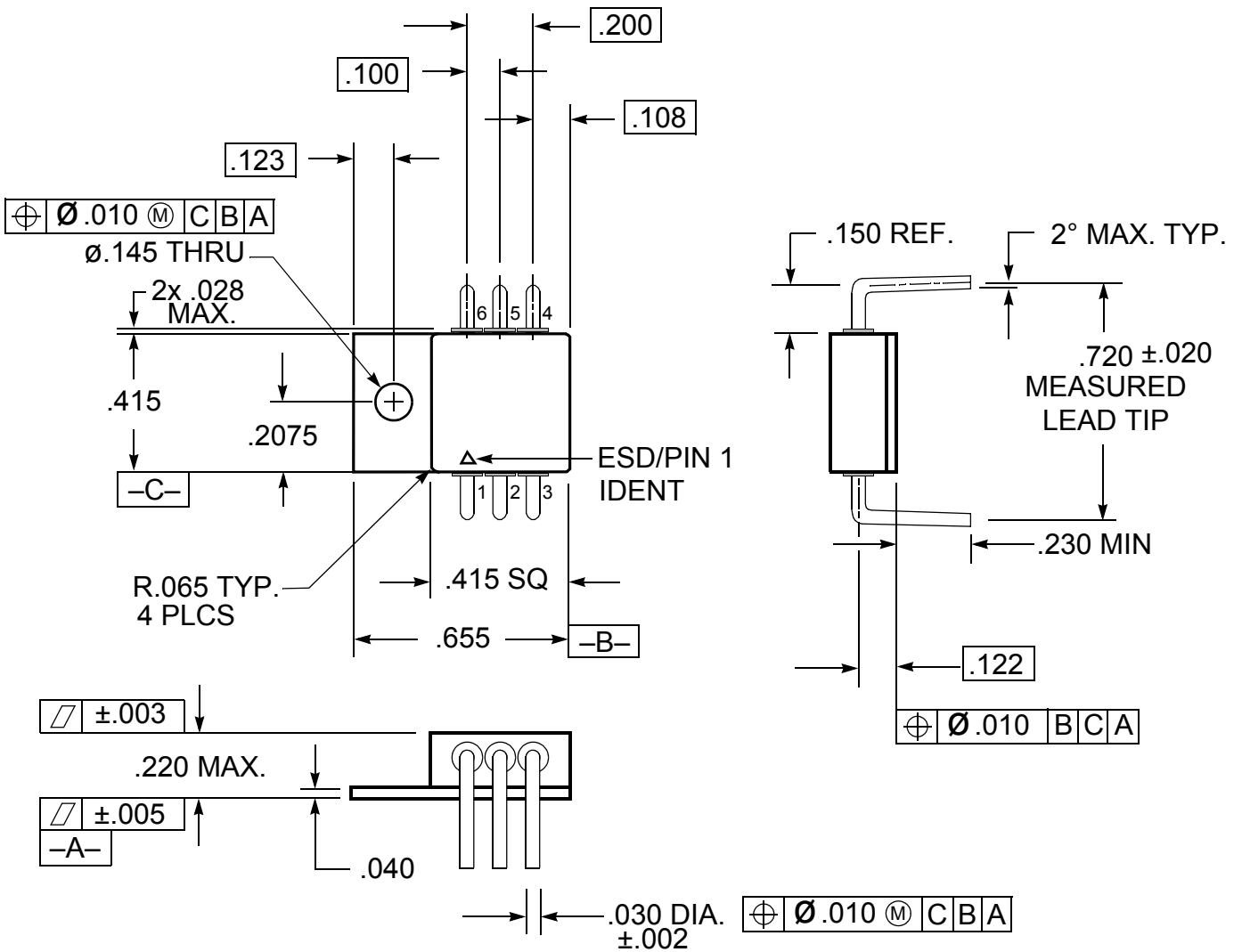

- Notes:
1. Dimension Tolerance:  $\pm.005$  inches
  2. Package contains BeO substrate
  3. Case electrically isolated

**FIGURE 4 – PACKAGE OUTLINE — THRU-HOLE POWER PACKAGE**

**TABLE II – PIN NUMBERS vs FUNCTION**

PIN	FUNCTION
1	NEG_ADJ_1
2	NEG_VOUT_1
3	NEG_VIN_1
4	NEG_ADJ_2
5	NEG_VIN_2
6	NEG_VOUT_2

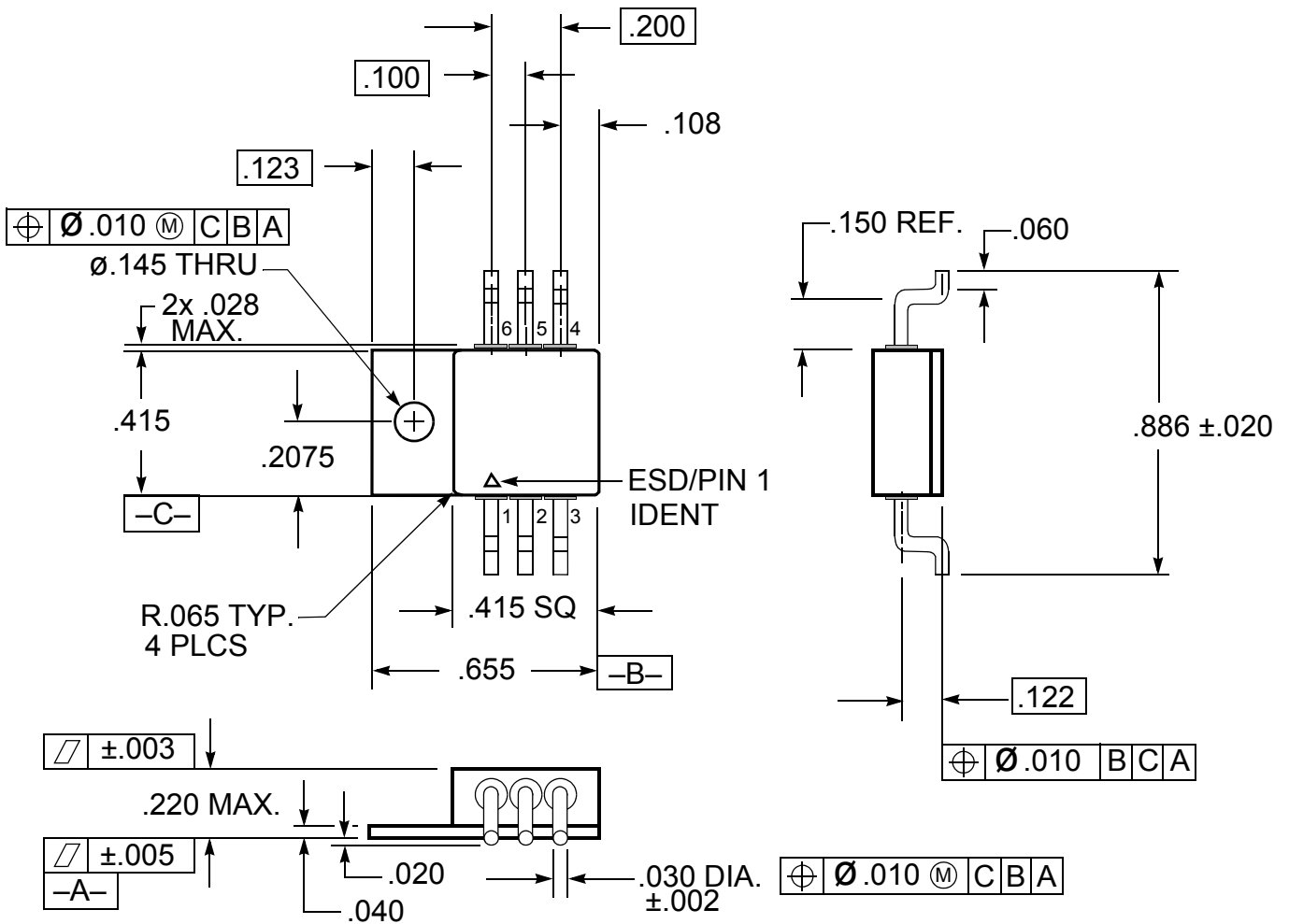

- Notes:
- 1. Dimension Tolerance: ±.005 inches
  - 2. Package contains BeO substrate
  - 3. Case electrically isolated

**FIGURE 5 – PACKAGE OUTLINE — SURFACE MOUNT POWER PACKAGE**

## ORDERING INFORMATION

MODEL	DLA SMD #	SCREENING	PACKAGE
VRG8609-7	-	Commercial Flow, +25°C testing only	6 Lead Thru-Hole Power Pkg
VRG8609-S	-	Military Temperature, -55°C to +125°C Screened in accordance with the individual Test Methods of MIL-STD-883 for Space Applications	
VRG8609-201-1S	5962-0521904KXC	In accordance with DLA SMD	
VRG8609-201-2S	5962-0521904KXA		
VRG8609-901-1S	5962R0521904KXC	In accordance with DLA Certified RHA Program Plan to RHA level "R", 100 krad(Si)	
VRG8609-901-2S	5962R0521904KXA		
VRG8610-7	-	Commercial Flow, +25°C testing only	6 Lead Surface Mount Power Pkg
VRG8610-S	-	Military Temperature, -55°C to +125°C Screened in accordance with the individual Test Methods of MIL-STD-883 for Space Applications	
VRG8610-201-1S	5962-0521904KYC	In accordance with DLA SMD	
VRG8610-201-2S	5962-0521904KYA		
VRG8610-901-1S	5962R0521904KYC	In accordance with DLA Certified RHA Program Plan to RHA level "R", 100 krad(Si)	
VRG8610-901-2S	5962R0521904KYA		

## REVISION HISTORY

Date	Revision	Change Description
03/24/2016	F	Import into Cobham format

## *Datasheet Definition*

**Advanced Datasheet - Product In Development**

**Preliminary Datasheet - Shipping Prototype**

**Datasheet - Shipping QML & Reduced Hi-Rel**

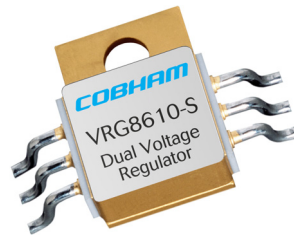

For detailed performance characteristic curves, applications information and typical applications, see the latest  datasheet for their RH137, which is available on-line at [www.linear.com](http://www.linear.com).

LT, LTC, Linear Technology and the Linear logo are registered trademarks and RH137 is copyright Linear Technology Corporation.

### **EXPORT CONTROL:**

*This product is controlled for export under the Export Administration Regulations (EAR), 15 CFR Parts 730-774. A license from the Department of Commerce may be required prior to the export of this product from the United States.*

**Cobham Semiconductor Solutions**  
35 S. Service Road  
Plainview, NY 11803

**E: [info-ams@cobham.com](mailto:info-ams@cobham.com)**  
**T: 800 645 8862**

**COBHAM**

Aeroflex Plainview Inc., DBA Cobham Semiconductor Solutions, reserves the right to make changes to any products and services described herein at any time without notice. Consult Aeroflex or an authorized sales representative to verify that the information in this data sheet is current before using this product. Aeroflex does not assume any responsibility or liability arising out of the application or use of any product or service described herein, except as expressly agreed to in writing by Aeroflex; nor does the purchase, lease, or use of a product or service from Aeroflex convey a license under any patent rights, copyrights, trademark rights, or any other of the intellectual rights of Aeroflex or of third parties.