

Standard Products

# UT28F64/LV and UT28F256/LV PROMs

Programming User Guide

Legacy Products

June 2011



## **PROM PROGRAMMING FLOW FOR UT28F64, UT28F256, UT28F64LV and UT28F256LV PROM for Legacy Products**

The UT28F64 and UT28F256 are 5-volt parts. The UT28F64LV and UT28F256LV are 5-volt parts that have been characterized for 3V operation. All four of these parts should follow the same flow for Post-Program Conditioning. These parts will be burned in at 7.0V and the Verify on the Prom Board Tester shall be performed at 4.5V and 5.5V. The UT28F64LV and UT28F256LV will not be damaged when tested at the higher voltages.

Parts are programmed and verified using a Data I/O 2900, 3900, 3980, or 3980xpi Programmer. After programming, the parts go through Post-Programming Conditioning (PPC). PPC is used to enhance the reliability (and radiation tolerance) of the Aeroflex UTMC PROMs following programming. PPC consists of a 64-hour unbiased bake and a 64-hour dynamic burn-in. Parts are verified using the Data I/O Programmer and the Aeroflex UTMC PROM Board Tester. This verification identifies parts that fail after PPC. The PROM Board Tester verifies the product by doing an at-speed test using the same functional test as the production tester. After the parts have been through this flow (see Figure 1), they are ready for use in your system.

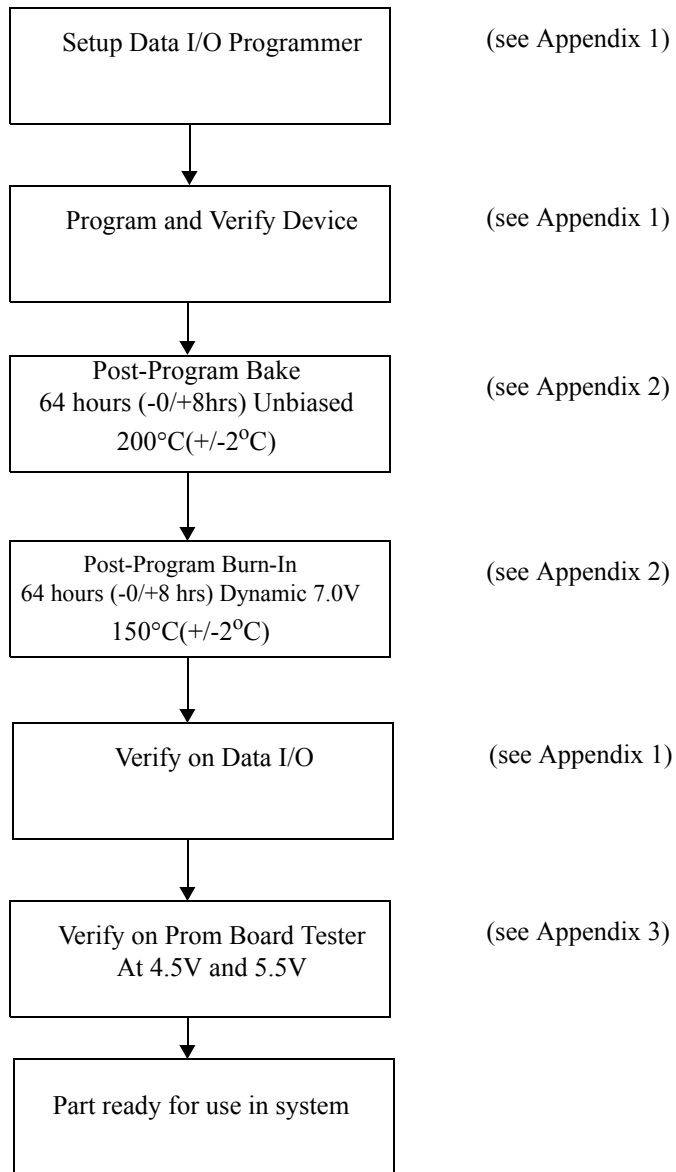

**Figure 1. PROM Programming Flow**

## APPENDIX 1

# DATA I/O Programming Set-Up Guide

The following reviews the installation of programming software for the UT28F64/UT28F256 and UT28F64LV/UT28F256LV PROM. To program the PROMs with an industry standard data file, the user simply loads the programming algorithm and data file into the DATA I/O programming hardware.

### HiTerm Software:

- 1) Insert diskette with appropriate algorithm into DATA I/O floppy drive.

From the Main Menu:

- 2) Choose: *Select Device* (This will bring up the Manufacturer List)
- 3) Choose: *UTMC* (This will bring up the part menu for UTMC)
- 4) From the Part Menu select:
  - UT28F256
  - UT28F256-FP
  - UT28F64
  - UT28F64-FP

### PROMlink or TASKLink Software:

- 1) Insert diskette with appropriate algorithm into DATA I/O floppy drive.
- 2) Choose *Setup* from the menu bar
- 3) From the *Setup* menu choose: *Select Device* (This will bring up a Manufacturer List)
- 4) From the *Manufacturer List* choose: *UTMC* (This will bring up a UTMC device menu)
- 5) Select one of the following device types from the *UTMC Device Menu*:
  - UT28F256
  - UT28F256-FP
  - UT28F64
  - UT28F64-FP

## Programming All Unused Bit Locations

Aeroflex UTMC requires that you program all bits in the UT28F64/UT28F256 and the UT28F64LV/UT28F256LV. If your program does not require all of the space within the PROMs, you should program the unused locations with a default value, or configure the DATA I/O programmer to write zero's to the unused bit locations. The following instructions describe the steps required by HighTerm, TaskLink, and PROMLink to properly configure the DATA I/O system to program zeros into all unused bit locations.

### HighTerm Software:

From the Main Menu:

- 1) Choose: *More Commands* (This will bring up a list of command menus)
- 2) Choose: *Edit Data* (This will bring up a list of data editing options)
- 3) Choose: *Fill Memory* (This will bring up the memory configuration options)
- 4) From the *Fill Memory* page:
  - Set *Memory Begin Address* to "0"
  - Set *Block Size* to "2000" (hexadecimal) (UT28F64/UT28F64LV)  
or Set *Block Size* to "8000" (hexadecimal) (UT28F256/UT28F256LV)
  - Set *Fill Variable* to "0"
  - Hit the [ENTER] key

### TaskLink/PROMLink Software:

- 1) Choose *Setup* from the menu bar
- 2) From the *Setup* menu choose: *Memory Parameters*  
(This will bring up memory configuration parameters)
- 3) Set the following option in the *Memory Parameters* menu:
  - Under "*Automatic RAM Fill*", click between the parenthesis ( ) next to "Specific: 00". You will see (●) next to "Specific: 00" when the item is properly selected. The default value for the RAM fill is 00h, and is displayed by the two zeros next to "Specific:". If you want the default fill value to be something other than 00h, you can click on the field next to "Specific:" and change the number to a desired hexadecimal value.

## Notes:

1. For programming, make sure that the continuity check, fuse verify and functional test are on. Failure to have these parameters properly set could result in an improperly programmed device that appears as a "PASS" after programming.

Setting up the programmer to perform continuity check and functional verification under HiTerm, PROMLink, and TASKLink is described below.

### In Highterm:

From the Main Menu:

- 1) Choose: More Commands (This will bring up a list of command menus)
- 2) Choose: Configure System (This will bring up a list of system configuration options)
- 3) Choose: Edit (This will bring up the option to set up the programming configuration)
- 4) Choose: Programming (This will bring up the the programming configuration options)
- 5) From the Edit Programming Parameters page:
  - Set Logic Verification to "A"
  - Set Continuity Check to "Y."

### In TASKLink/PROMLink:

From the Main Menu Bar:

- 1) Choose: Setup
- 2) From the Setup menu choose: General Parameters  
(This will show general programmer configuration settings)
- 3) Set the following options in the General Parameters menu:
  - Set Verify Passes to "TWO VCC LOW/HIGH."
  - Click on the Check Box next to Continuity Checking  
(The box should have an "X" when enabled.)

Now **return** to the Setup menu, and perform the following:

- 1) From the Setup menu choose: Logic Parameters:
- 2) Configure the following option from the Logic Parameter menu:
  - Set Verify Options to "FUSE VERIFY AND FUNCTIONAL TEST."
2. If the part fails continuity when attempting to program, try again with the part reseated in the socket. If that fails, make sure the part is correctly oriented in the Data I/O programmer. DIPs must be oriented as per the diagram on the programmer base. Flatpack parts must be oriented in their carriers correctly (see attached carrier orientation diagram).
3. The DATA I/O 2900, 3900, 3980, 3980xpi "Blank Check" utility does not function properly on the UT28F64/LV and UT28F256/LV PROM.
4. Programmer Pin Interface (PPI) boards are available from DATA I/O. (see Table 1)

### UT28F64/LV and UT28F256/LV PROM Alignment Within Carrier

The following diagram shows the alignment of the UT28F64/UT28F256 and UT28F64LV/UT28F256LV PROM within its carrier. It is very important that the PROM is properly aligned in the carrier during programming. If you attempt to program the PROM when it is not properly aligned, the Data I/O programmer will fail continuity check.

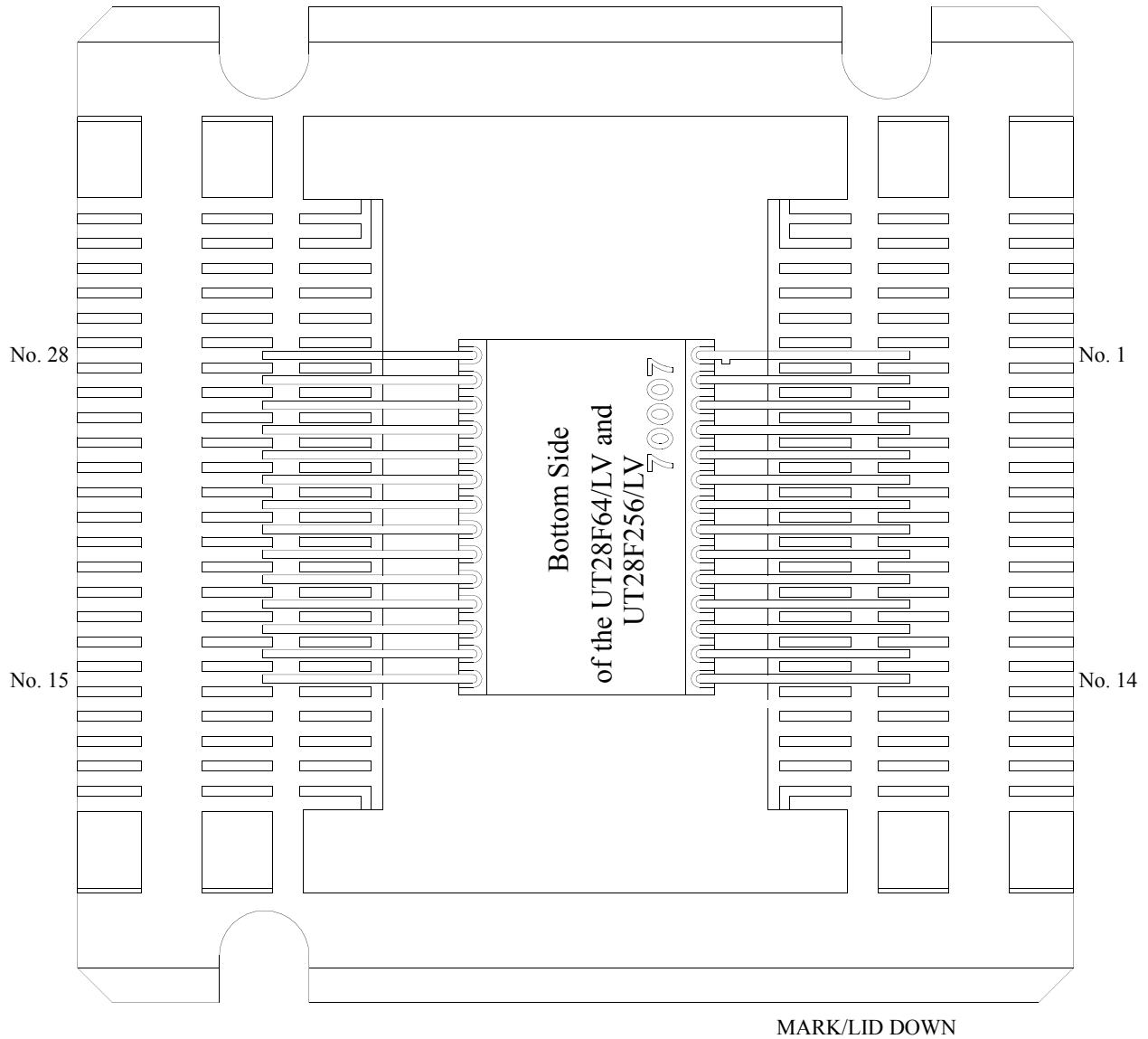

**Figure 2. Diagram of the UT28F64/LV and UT28F256/LV PROM 28 Pin Flat Pack in Carrier**

## Programmer Options

Data I/O supports PROM on the following programmers:

2900  
3900  
3980  
3980xpi

**Table 1: DATA I/O Platforms for PROM**

<b>Product Type</b>	<b>DATA I/O 2900</b>	<b>DATA I/O 3900, 3980 and 3980xpi</b>	<b>DATA I/O Uni-Site</b>
PROM	Yes  <u>DIP BASE:</u> 29BASE-0102  <u>PPI BASE:</u> 29BASE 9901 PPI-1004 (FP)	Yes  <u>DIP BASE:</u> 39BASE-0101  <u>PPI BASE:</u> 39BASE 9901 PPI-1004 (FP)	Not Available

## APPENDIX 2

# UTRH00SC Burn-In Stimulus Controller

## Stimulus Controller and Post-Program Conditioning Operating Instructions

### Introduction:

The following reviews the setup and operation of the PROM Burn-In Stimulus Controller, and discusses the post-program conditioning process. The Stimulus Controller is used to supply all the appropriate signals to the PROM Burn-In boards during post-program conditioning. The post-program conditioning is required to optimize the performance, and increase the reliability of the UT28F64/LV and UT28F256/LV PROMs.

### Stimulus Controller Setup:

Please refer to Figure 1 to assist with these instructions.

- 1) Insert the PROMs into the burn-in board using standard ESD procedures.
- 2) The burn-in board is supplied with approximately 5 feet of Teflon ribbon cable. The cable and burn-in board will withstand 152°C maximum temperature. Place the cable through the port of the burn-in oven, with the burn-in board on a flat surface.
- 3) Connect the Teflon ribbon cable from the burn-in board to one of the connectors on the Stimulus Controller. The Stimulus Controller is capable of driving two burn-in boards. Note that the cable connector is keyed such that the notch will face away from the power jacks.
- 4) Supply power to the Stimulus Controller using two banana plug cables. The power supply must limit a maximum of 1 Amp of current at +12VDC (-0V/+0.5V). Insert the cable attached to the GROUND output of the power supply to the BLACK banana jack located on the end of the Stimulus Controller. Insert the cable attached to the +12Volt output of the power supply to the RED banana jack located on the end of the Stimulus Controller. Turn on the power supply and verify that the POWER ON LED is lit up, and that the FREQ. ON LED is flashing. Check the burn-in board with a voltmeter between the GND and the PS1 (VDD) terminals for 7.0VDC (-0.2V/+0V). Turn off the power supply.
- 5) The post-program Stimulus Controller is now ready for operation. After the burn-in oven has reached 150°C, turn on the power supply and check the voltages as in step 4 above. Be careful not to be harmed by hot metal surfaces in the oven as you verify that there is 7.0VDC (-0.2V/+0V) between the PS1 and GND terminals on the burn-in board.

**NOTE:** Verify that the power supply is set to +12VDC (-0V/+0.5V) before applying power to the Stimulus Controller.

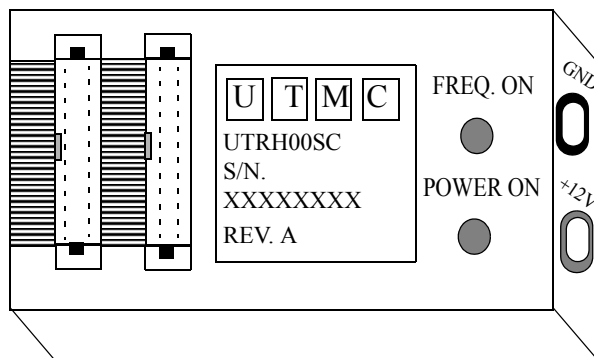

Figure 1. Aeroflex UTMC Stimulus Controller



**Post-Program Conditioning Flow:**

The post-program conditioning is a very important step in the PROM programming process. It performs two major tasks:

- 1) Increases the reliability of the UT28F64/LV and UT28F256/LV PROM
- 2) Optimizes the performance of the UT28F64/LV and UT28F256/LV PROM

The required post-programming flow is shown on page 1 of the User Guide. The user first programs the UT28F64/LV and UT28F256/LV PROM on either the DATA I/O 2900, or the DATA I/O 3900/3980/3980xpi programmer.

Then the PROMs are placed on a tray suitable for burn-in temperatures, loaded into the burn-in oven, and are run through a 64 hour (-0/+8Hrs), unbiased, post-program bake at 200°C ( $\pm 2^{\circ}\text{C}$ )\*. The PROM does not need to be removed from the carrier.

Following this bake process, the temperature is decreased to 150°C ( $\pm 2^{\circ}\text{C}$ ), the PROMs are loaded into the burn-in board, and the Stimulus Controller is connected to the teflon ribbon cable on the burn-in board. Now the user will perform a 64 hour dynamic burn-in with the stimulus applied to the burn-in board.

Finally, the user will remove the PROMs from the burn-in board, and verify full functionality with the DATA I/O programmer and the PROM Board Tester.

**Note:** The burn-in board is only good up to 152°C maximum.

## The Dynamic Burn-In Circuit:

The dynamic burn-in circuit is shown in Table 1 and Table 2. The circuit describes the bias to each pin of the UT28F64/LV and UT28F256/LV PROM and the frequency that the stimulus is applied. Additionally, the power supply voltage ( $V_{DD}$ ) is set by the Stimulus Controller at 7.0VDC +0/-0.2V, and the temperature for the burn-in process is described in the post-program conditioning flow (Figure 2) as 150°C ±2°C. The stimulus duty cycle is 50% ±10% except for  $\overline{PE}$ , and the dynamic frequency tolerance is ±10%. See Figures 3 and 4, for a description of the dynamic burn-in timing.

**Table 1. UT28F64/LV Dynamic Burn-In Circuit**

Pin	Signal Name	I/O Type	Series Resistor	Dynamic
1	NC	Input	2.49K $\Omega$	NC
2	A12	Input	2.49K $\Omega$	48.8Hz
3	A7	Input	2.49K $\Omega$	1.56KHz
4	A6	Input	2.49K $\Omega$	3.13KHz
5	A5	Input	2.49K $\Omega$	6.25KHz
6	A4	Input	2.49K $\Omega$	12.5KHz
7	A3	Input	2.49K $\Omega$	25KHz
8	A2	Input	2.49K $\Omega$	50KHz
9	A1	Input	2.49K $\Omega$	100KHz
10	A0	Input	2.49K $\Omega$	200KHz
11	DQ0	BiDirect	2.49K $\Omega$	6.1Hz
12	DQ1	BiDirect	2.49K $\Omega$	6.1Hz
13	DQ2	BiDirect	2.49K $\Omega$	6.1Hz
14	VSS	Ground	N/A	Ground
15	DQ3	BiDirect	2.49K $\Omega$	6.1Hz
16	DQ4	BiDirect	2.49K $\Omega$	6.1Hz
17	DQ5	BiDirect	2.49K $\Omega$	6.1Hz
18	DQ6	BiDirect	2.49K $\Omega$	6.1Hz
19	DQ7	BiDirect	2.49K $\Omega$	6.1Hz
20	/CE	Input	2.49K $\Omega$	Ground
21	A10	Input	2.49K $\Omega$	195Hz
22	/OE	Input	2.49K $\Omega$	VDD
23	A11	Input	2.49K $\Omega$	97.7Hz
24	A9	Input	2.49K $\Omega$	391Hz
25	A8	Input	2.49K $\Omega$	781Hz
26	NC	Input	2.49K $\Omega$	NC
27	/PE	Input	2.49K $\Omega$	400KHz
28	VDD	Power	N/A	VDD

VDD = 7.0 + 0/- 0.2V

Temperature = 150 degrees Celsius

Time 64 hours -0/+8hrs

Duty Cycle 50% +/-10% except for /PE

Dynamic Frequency Tolerance = +/-10%

**Table 2. UT28F256/LV Dynamic Burn-In Circuit**

Pin	Signal Name	I/O Type	Series Resistor	Dynamic
1	A14	Input	2.49K $\Omega$	12.2Hz
2	A12	Input	2.49K $\Omega$	48.8Hz
3	A7	Input	2.49K $\Omega$	1.56KHz
4	A6	Input	2.49K $\Omega$	3.13KHz
5	A5	Input	2.49K $\Omega$	6.25KHz
6	A4	Input	2.49K $\Omega$	12.5KHz
7	A3	Input	2.49K $\Omega$	25KHz
8	A2	Input	2.49K $\Omega$	50KHz
9	A1	Input	2.49K $\Omega$	100KHz
10	A0	Input	2.49K $\Omega$	200KHz
11	DQ0	BiDirect	2.49K $\Omega$	6.1Hz
12	DQ1	BiDirect	2.49K $\Omega$	6.1Hz
13	DQ2	BiDirect	2.49K $\Omega$	6.1Hz
14	VSS	Ground	N/A	Ground
15	DQ3	BiDirect	2.49K $\Omega$	6.1Hz
16	DQ4	BiDirect	2.49K $\Omega$	6.1Hz
17	DQ5	BiDirect	2.49K $\Omega$	6.1Hz
18	DQ6	BiDirect	2.49K $\Omega$	6.1Hz
19	DQ7	BiDirect	2.49K $\Omega$	6.1Hz
20	/CE	Input	2.49K $\Omega$	Ground
21	A10	Input	2.49K $\Omega$	195Hz
22	/OE	Input	2.49K $\Omega$	VDD
23	A11	Input	2.49K $\Omega$	97.7Hz
24	A9	Input	2.49K $\Omega$	391Hz
25	A8	Input	2.49K $\Omega$	781Hz
26	A13	Input	2.49K $\Omega$	24.4Hz
27	/PE	Input	2.49K $\Omega$	400KHz
28	VDD	Power	N/A	VDD

VDD = 7.0 + 0/- 0.2V

Temperature = 150 degrees Celsius

Time 64 hours -0/+8hrs

Duty Cycle 50% +/-10% except for /PE

Dynamic Frequency Tolerance = +/-10%

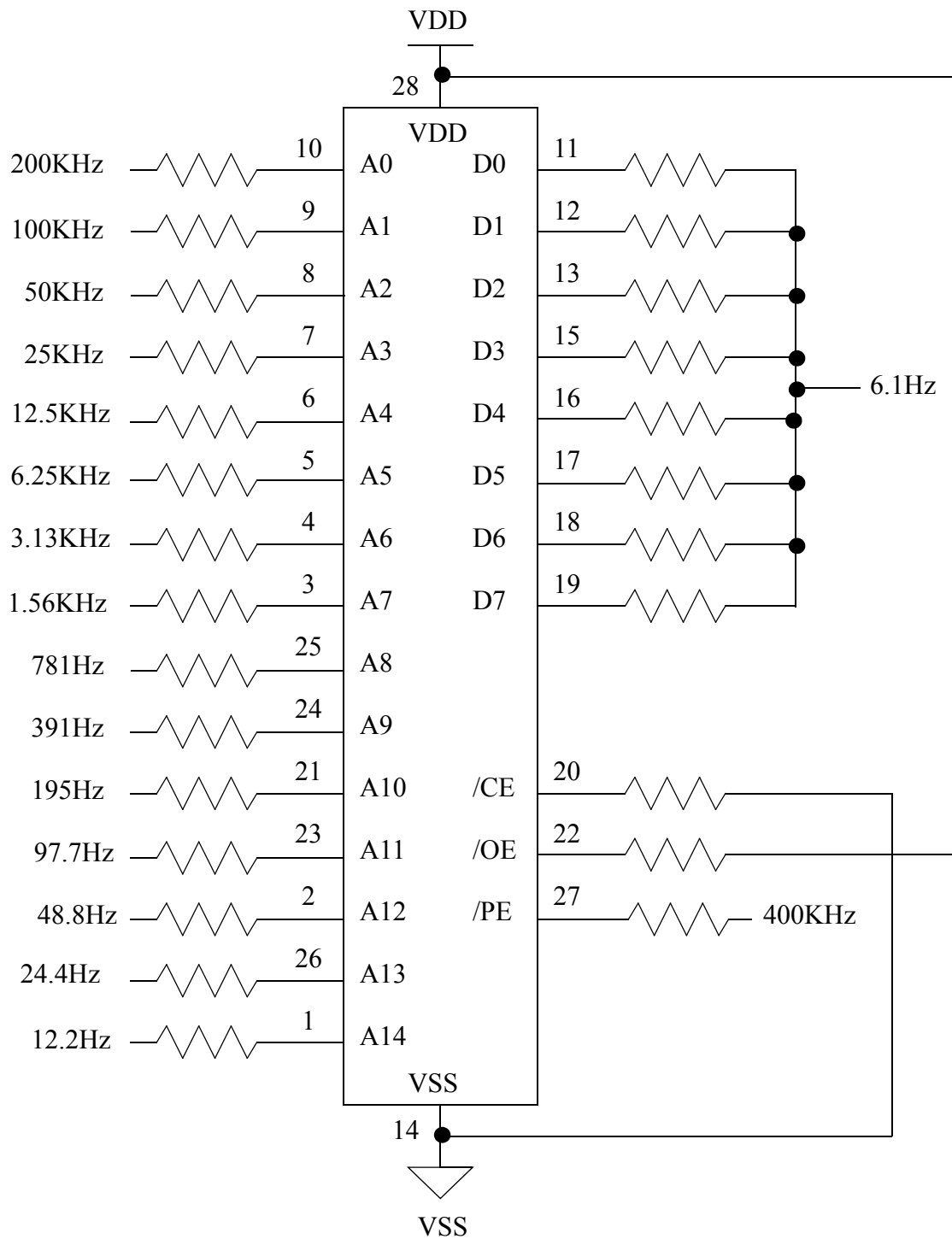

**Figure 2. UT28F64/LV and UT28F256/LV PROM BURN-IN CIRCUIT**

**Note:** All resistors = 2.49K, Pins 1 and 26 are no connects for the UT28F64/LV

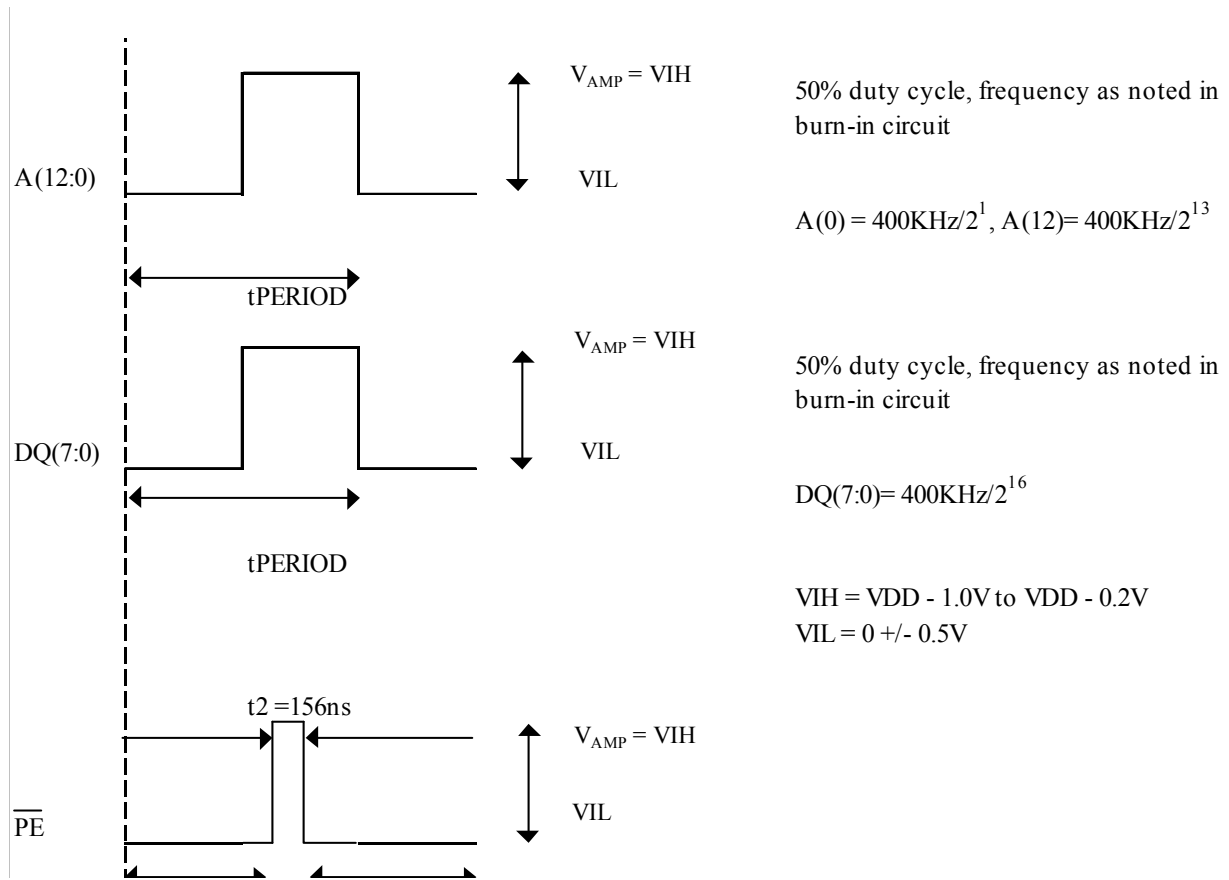
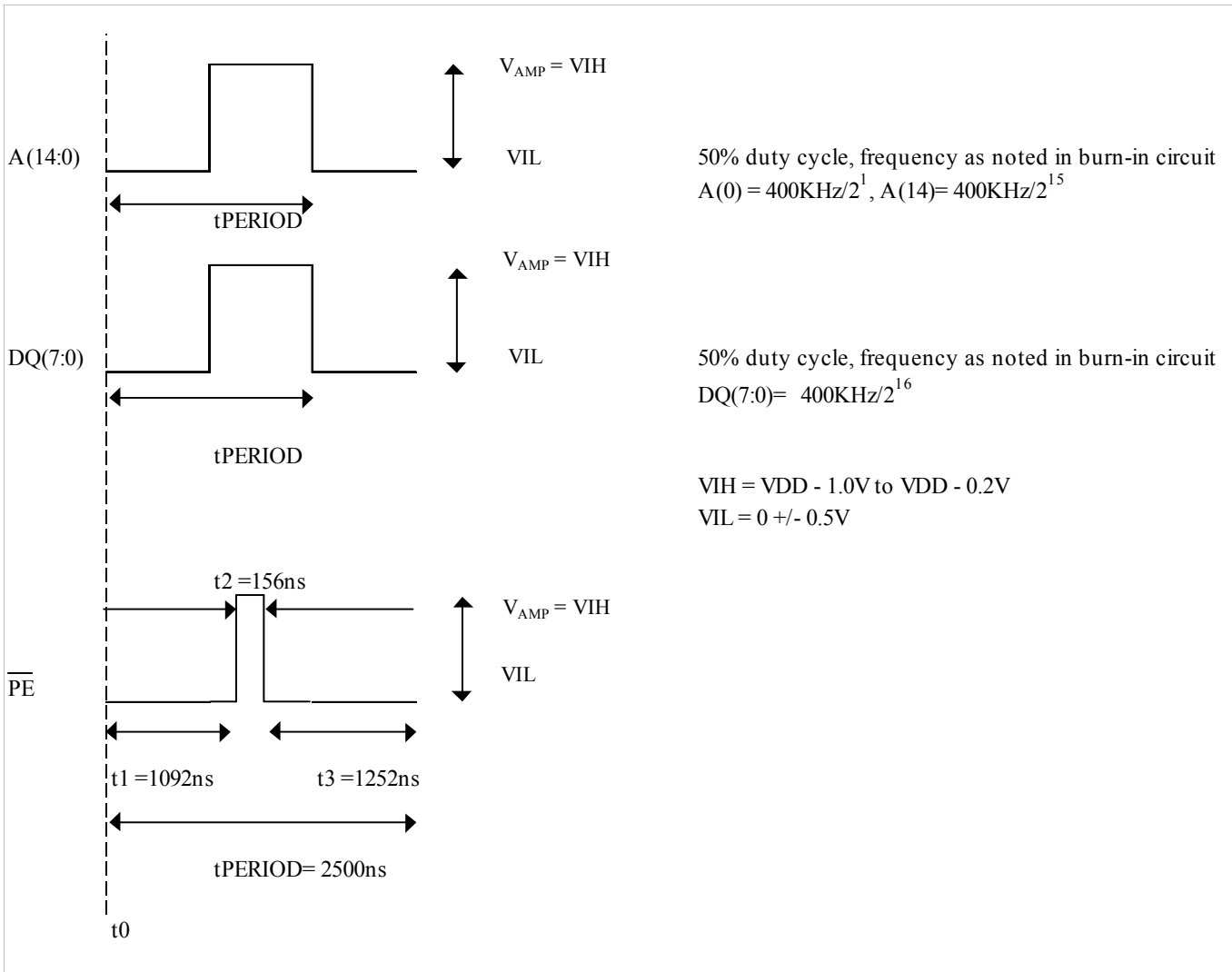

Figure 3. UT28F64/LV Dynamic Burn-In Timing



**Figure 4. UT28F256/LV Dynamic Burn-In Timing**

## APPENDIX 3

# PROM BOARD USER GUIDE

### INTRODUCTION

The PROM Board Tester is used to verify all antifuses are programmed reliably after the PROM has been through Post-Programming Conditioning.

The PROM data is read into the SRAM at 1.5mS for the initial capture of the PROM contents.  $\overline{CE}$  and  $\overline{OE}$  are held active during this read. The PROM is then read in again at 25ns. During this read,  $\overline{CE}$  and  $\overline{OE}$  switch during each read cycle. This is a worst case read condition for this part. The contents of the SRAM are compared for the low speed read and the high speed read. If there are any differences they will be displayed with address location and data for that location. The user can then step through any additional failures.

### TEST PROCEDURE

1. Turn on main power switch, S1.
2. Hit Reset, S4.
3. Parts must be tested at 4.5V and 5.5V. (**Note:** PROM test voltage is determined by power supply voltage supplied to the board. UT28F64LV and UT28F256LV PROMs must be tested at 4.5V and 5.5V. The parts will not be damaged by the higher VDD).
4. Place part in socket (Address lines are in tristate mode on FPGA).
5. Turn on PROM Power switch, S2.
6. Hit Reset, S4.
7. Hit Start, S3.
8. If Error Count is 0, complete light will come on.
9. If Error Count is greater than 0, hit Step button, S5, to review all errors.
10. Complete light, D1, will come on when all errors have been reviewed.
11. Turn off Prom Power, S2, and go to step 4.

# PROM VERIFICATION BOARD

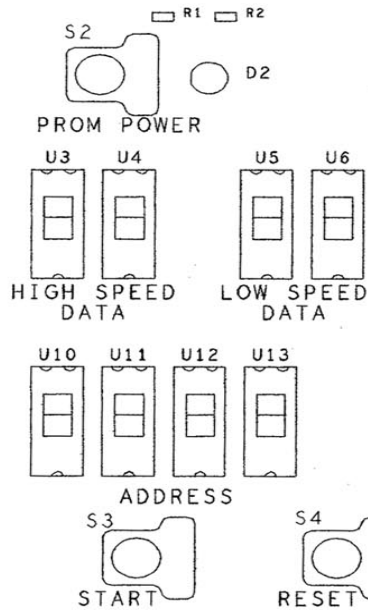
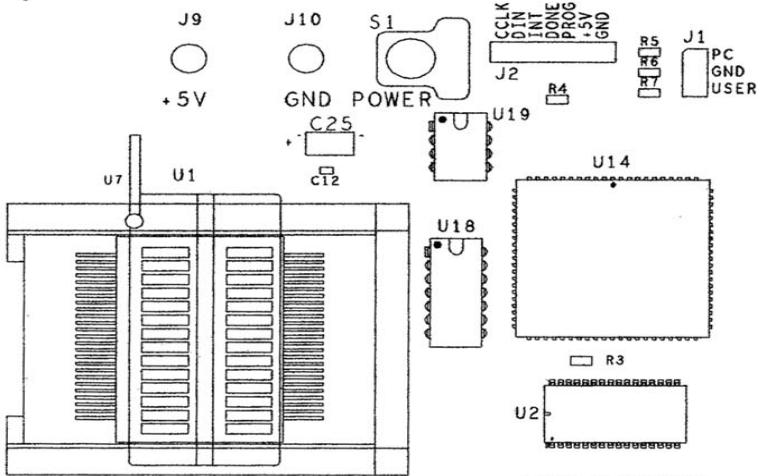

## TEST PROCEDURE

- 1) TURN ON MAIN POWER SWITCH.
- 2) HIT RESET.
- 3) PARTS SHOULD BE TESTED AT 4.5 AND 5.5VDC.
- 4) PLACE PART IN SOCKET (ADDRESS LINES ARE IN TRISTATE MODE ON FPGA).
- 5) TURN ON PROM POWER.
- 6) HIT RESET.
- 7) HIT START.
- 8) IF ERROR COUNT IS 0 THEN COMPLETE LIGHT WILL COME ON.
- 9) IF ERROR COUNT IS GREATER THAN 0 THEN HIT STEP BUTTON TO REVIEW ALL ERRORS.
- 10) COMPLETE LIGHT WILL COME ON WHEN ALL ERRORS HAVE BEEN REVIEWED.
- 11) TURN OFF PROM POWER AND GOTO STEP 4.



# PROM PROGRAMMING KITS - ORDER INFORMATION

**Listed below are the part numbers to order the PROM Programming Kits for the  
UT28F256, UT28F256LV, UT28F64, AND UT28F64LV PROMs**

**RH00VK** Flat Pack Post Programming Conditioning Kit

Verification Card  
4.5 foot cable  
Stimulus Card  
1/2 Size FP B/I Board  
Instruction Manual

**RH01VK** DIP Post Programming Conditioning Kit

Verification Card  
4.5 foot cable  
Stimulus Card  
1/2 Size DIP B/I Board  
Instruction Manual

**Listed below are the part numbers to order additional burn-in boards**

**RH00DPBB** DIP Burn-in Board

1/2 size burn-in board is 13.50" by 11.45" and contains approximately 18 DIP sockets.  
Instruction Manual

**RH00FPBB** Flat Pack Burn-in Board

1/2 size burn-in board is 13.50" by 11.45" and contains approximately 12 flat pack sockets.  
Instruction Manual

**Listed below are the part numbers to order Cards and Cable**

**RH00SC** Stimulus Card

Burn-in board stimulus card, operates on a single DC supply voltage of 12VDC.  
Instruction Manual

**RH00VB** Verification Card

Verification card, operates on a single DC supply voltage  
Instruction Manual

**RH00CB** Cable

4.5 foot teflon ribbon cable  
Instruction Manual

**COLORADO**

Toll Free: 800-645-8862  
 Fax: 719-594-8468

**INTERNATIONAL**

Tel: 805-778-9229  
 Fax: 805-778-1980

**NORTHEAST**

Tel: 603-888-3975  
 Fax: 603-888-4585

**SE AND MID-ATLANTIC**

Tel: 321-951-4164  
 Fax: 321-951-4254

**WEST COAST**

Tel: 949-362-2260  
 Fax: 949-362-2266

**CENTRAL**

Tel: 719-594-8017  
 Fax: 719-594-8468

[www.aeroflex.com](http://www.aeroflex.com)     [info-ams@aeroflex.com](mailto:info-ams@aeroflex.com)

Aeroflex Colorado Springs, Inc., reserves the right to make changes to any products and services herein at any time without notice. Consult Aeroflex or an authorized sales representative to verify that the information in this data sheet is current before using this product. Aeroflex does not assume any responsibility or liability arising out of the application or use of any product or service described herein, except as expressly agreed to in writing by Aeroflex; nor does the purchase, lease, or use of a product or service from Aeroflex convey a license under any patent rights, copyrights, trademark rights, or any other of the intellectual rights of Aeroflex or of third parties.



Our passion for performance is defined by three attributes represented by these three icons: solution-minded, performance-driven and customer-focused