

BEU8642-EVAL

Balancing for 8-Cell Battery
Cell Voltage Monitoring
Temperature Monitoring

www.aeroflex.com/BEU

January 29, 2009

AEROFLEX
A passion for performance.

Description

The Aeroflex 8642-EVAL is a Lithium-Ion battery cell balancer. It provides voltage balancing among eight series stacked cells within a multi-cell battery to actively drive the voltage of each cell towards the average voltage of all cells using a patented charge-sharing technology.

Features

- Cell Balancing of eight series stacked Lithium-Ion cells
- Transfer Ratio: 1 ohm nominal
- Cell Balancing to within ± 10 mV
- Temperature Monitoring
- Cell Voltage Monitoring with high cell and low cell detection
- Built In Test (BIT) Discrete Output
- Suitable for a wide range of cell capacities, from less than 1 A-h to greater than 200 A-h
- RS-232 Output for data logging
- LCD Display for cell voltages, temperatures and status



Benefits

When Lithium-Ion battery cells are charged and discharged, small differences in the internal electrical characteristics of each cell may lead to cell voltage differences. At beginning of life, battery manufacturers take great care to match the cell characteristics very precisely. After many charge cycles, the characteristics diverge, causing cell voltage imbalances. Since the battery can only be charged until the highest cell reaches the maximum allowed voltage, the remaining cells are never fully charged. Similarly, as the battery is discharged, the battery must be disconnected when the lowest cell reaches the minimum allowed voltage, thereby preventing the charge in the remaining cells from being used.

By keeping the cells balanced the useful capacity and life of the battery are maximized.

The 8642-EVAL provides continuous balancing for maximum protection against non-balance of Lithium-Ion cells.

Safety

The 8642-EVAL incorporates fuses to protect the battery in the event of a balancing circuit failure, as well as fuses to protect the 8642-EVAL if a battery cell fails.

The maximum balancing current supplied by the 8642-EVAL is 1A. All cells must be balanced to be within 1V before connecting the 8642-EVAL to the battery.

High cell detection can be used to prevent overcharging. Low cell detection can be used to prevent deep discharge.

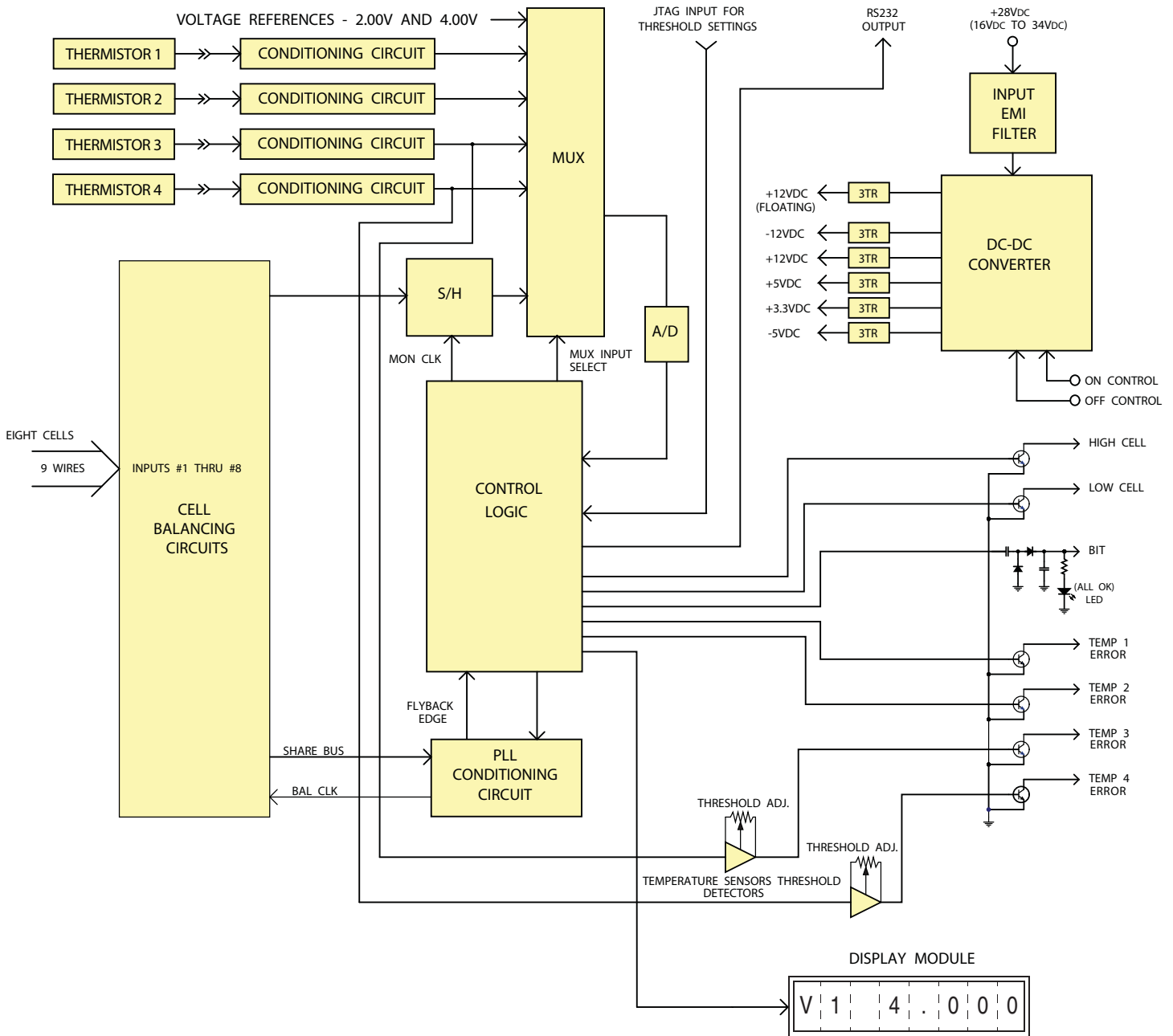

Balancer Block Diagram

Organization and Application

The Aeroflex BEU8642-EVAL contains eight cell balancing circuits. Each cell balancing circuit is connected in parallel with one of the stacked cells of a multi-cell Lithium-Ion battery. In operation, energy is shared among the cells of the battery by way of the balancing circuits.

The point in the circuit of energy exchange is called the Share Bus, which represents the average voltage of all the cells. Those cells having higher voltages deliver energy to the Share Bus while those cells with lower voltages receive energy from the Share Bus.

The nominal impedance between each cell and the Share Bus, also known as the transfer ratio, is 1 ohm. This ratio determines the amount of balancing current and is based on the voltage difference between each cell and the Share Bus. For example a cell that is 200mV higher than the Share Bus will deliver 200mA to the Share Bus, whereas a cell that is 100mV less than the Share Bus will receive 100mA charging current from the Share Bus.

Technical Specifications

A. Cell Balancing

Number of Cells:	8
Transfer Ratio:	1 ohm nominal (0.8 ohms to 1.39 ohms)
Cell Voltage Range:	2.0 volts to 4.5 volts
Cell Balancing Current:	1.0 amperes maximum

B. Cell Voltage Monitoring

Discrete Cell Voltage Monitor Outputs:	There are two discrete Cell Voltage Monitor Outputs: High Cell (HC) and Low Cell (LC). Each output circuit is an NPN transistor, rated at 100 mA and 40 VDC, suitable for driving an LED. The transistor turns on when the measured cell voltage of any cell is outside the set limits. For example, if the HC limit is set at 4.200 volts, the transistor turns on if any measured cell voltage is greater than 4.200 volts. If the LC limit is set at 3.200 volts, the transistor turns on if any measured cell voltage is lower than 3.200 volts.
Hysteresis:	Each detection circuit has a hysteresis of 30 mV. For example, the HC limit turns on when any cell voltage exceeds 4.200 volts. It remains on until the voltage drops below 4.170 volts.
Voltage Measurement Accuracy:	Cell voltage monitoring accuracy is ± 10 mV, over the range of 2.000 volts to 4.500 volts.

C. Temperature Monitoring

Number of sensors:	4 (Typically located in battery)
Sensor Type:	NTC Thermistor Type: Keystone RL0503-55.36K-122-MS2 100K Ω
Thresholds:	Each sensor has an Upper Threshold (UT) and a Lower Threshold (LT). For example, the UT may be set at 70°C and the LT may be set at 0°C.
Processing:	Threshold voltages for Sensors 1 and 2 are set by the Control Logic. Thresholds for Sensors 3 and 4 are set by separate analog circuits. The Sensor 1, 2 circuits and the Sensor 3, 4 circuits are independent, so that a failure in either section does not affect the performance of the other section.
Setting of Analog Thresholds:	The analog thresholds (Sensors 3 and 4) are set by potentiometers, with resolution of 1°C.
Temperature Accuracy:	Measurement accuracy of the 8642-EVAL unit (independent of the accuracy of the thermistors) is less than $\pm 3^\circ\text{C}$, over the range of -10°C to $+80^\circ\text{C}$.
Discrete Temperature Monitor Outputs:	There are four Temperature Sensor Monitor outputs (one for each sensor). Each output circuit is an NPN transistor, rated at 100 mA and 40 VDC, suitable for driving an LED. The transistor turns on when the measured temperature is outside the set limits. For example, if the limits are set at 0°C and 70°C, the transistor is off when the temperature is between 0°C and 70°C, and turns on when the temperature is less than 0°C or greater than 70°C, within the specified accuracy limits.

D. Built In Test (BIT) Discrete Output

- BIT Functions:** The Control Logic autonomously performs a series of internal tests to verify that the circuits are operating correctly. These tests include measuring:
- 2V reference
 - 4V reference
 - Power Supply Monitor
 - PLL frequency
 - PLL closed loop
 - Open/shorted temperature sensors (all 4)
- BIT Output:** The "All OK" LED is lit and the discrete output is high when no errors are detected by BIT.

E. Power Supply

- Input Voltage:** The balancing unit meets all functional requirements for input voltages from 16.0 VDC to 34.0 VDC.
- Brownout Protection:** No damage (to either the 8642-EVAL card or the battery) can occur for any input voltage between 0 VDC and 34.0 VDC.

F. On/Off Control Circuit

- Latching Relay:** A latching relay is included on the card. When this relay is latched (turned on), the DC-DC converter output voltages are on, and the balancing card operates. When the latching relay is reset (turned off), the balancing card is inactive. The latching relay is magnetically latched, and maintains its state without power.
- On Command:** The On command must be a pulse with amplitude of 16.0 volts to 34.0 volts and pulse width of 10.0 milliseconds or greater.
- Off Command:** The Off command must be a pulse with amplitude of 16.0 volts to 34.0 volts and pulse width of 10.0 milliseconds or greater.

G. Settings in Nonvolatile Memory

- Nonvolatile Memory:** The Control Logic contains a nonvolatile memory which holds settings for certain functions. These settings can be customized at the factory. These settings include the following:
- 1) Hi Cell limit (1.25mV/bit)
 - 2) Lo Cell limit (1.25 mV/bit)
 - 3) Hi Temp 1 limit (2's complement degrees C)
 - 4) Lo Temp 1 limit (2's complement degrees C)
 - 5) Hi Temp 2 limit (2's complement degrees C)
 - 6) Lo Temp 2 limit (2's complement degrees C)
 - 7) Hi/Lo Cell hysteresis (1.25mV/bit)
 - 8) In Balance limit (1.25mV/bit)
 - 9) Out of Balance limit (1.25mV/bit)
 - 10) Balancing duty cycle $[1/(n+1)]$

H. Panel LED Indicators.

LED Indicators:

There are 8 LEDs on the top panel of the 8642-EVAL for quick status of the following parameters:

- 1) BALANCE ACTIVE: This LED is on when the balancer clock is functioning properly.
- 2) ALL OK: This LED is on when there are no errors detected by the BIT circuit, which monitors the following parameters:
 - a. 2V internal reference
 - b. 4V internal reference
 - c. Power Supply Monitor
 - d. PLL frequency
 - e. PLL closed loop
 - f. Open or shorted temperature sensors (all 4)
- 3) TEMPERATURE ERROR 4: This LED is on when the temperature sampled by sensor 4 is not within the range set by sensor 4's upper and lower thresholds.
- 4) TEMPERATURE ERROR 3: This LED is on when the temperature sampled by sensor 3 is not within the range set by sensor 3's upper and lower thresholds.
- 5) TEMPERATURE ERROR 2: This LED is on when the temperature sampled by sensor 2 is not within the range set by sensor 2's upper and lower thresholds.
- 6) TEMPERATURE ERROR 1: This LED is on when the temperature sampled by sensor 1 is not within the range set by sensor 1's upper and lower thresholds.
- 7) LOW CELL: This LED will be on when the voltage on any of the 8 cells falls below 3.20 volts.
- 8) HIGH CELL: This LED will be on when the voltage on any of the 8 cells exceeds 4.20 volts

I. Serial Output

RS232 Serial Digital Output:

Continuously outputs the following values:

2V reference voltage
4V reference voltage
Cell 1 voltage
Cell 2 voltage
Cell 3 voltage
Cell 4 voltage
Cell 5 voltage
Cell 6 voltage
Cell 7 voltage
Cell 8 voltage
Thermistor 1 temperature
Thermistor 2 temperature
Thermistor 3 temperature
Thermistor 4 temperature
Power supply monitor voltage

These values are outputted in a comma-separated value ASCII format at 115.2K BAUD, 1 stop bit and no parity.

Each measurement is updated approximately every 30 seconds.

J. LCD Display

Continuously outputs the following values:

- Built-in test status
- 2V reference voltage
- 4V reference voltage
- Cell 1 voltage
- Cell 2 voltage
- Cell 3 voltage
- Cell 4 voltage
- Cell 5 voltage
- Cell 6 voltage
- Cell 7 voltage
- Cell 8 voltage
- Thermistor 1 temperature
- Thermistor 2 temperature
- Thermistor 3 temperature
- Thermistor 4 temperature
- Power supply monitor voltage

K. Preconditioning

Function: A voltage applied between this pin and CELL_RTN, to pre-charge the input capacitors to match each balancer cell's voltage with its mating battery cell's voltage, which prevents large in-rush currents when the battery is connected to the balancer.

L. Mechanical Requirements

Mechanical Size: The dimensions of the BEU8642-EVAL are in accordance with the box outline. The edge measurements are as follows:

Length: 12.00"

Width: 9.00"

Height: 2.65"

Connector Types: Tyco Electronics-Amp – 206151-1 On unit
– 206150-1 Mating Connector

Pinouts and Description

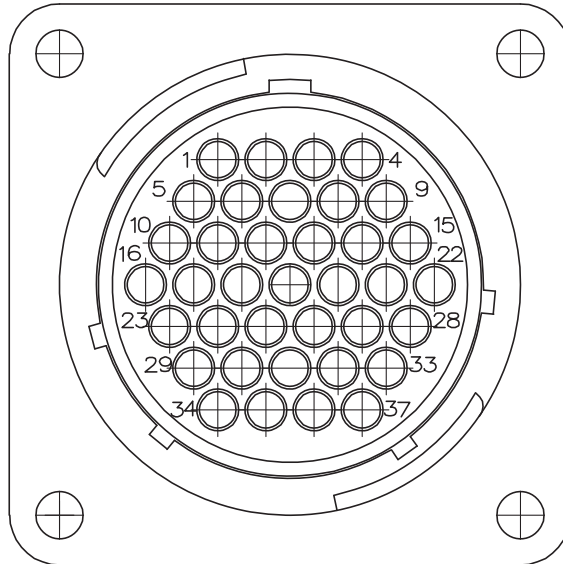

External view of male connector
mounted on 8642-EVAL unit

Pin #	Description	Pin #	Description	Pin #	Description	Pin #	Description
1	CELL 2+	11	TEMP ERR 1	21	LOW CELL	31	NC
2	CELL 4+	12	TEMP ERR 2	22	BIT	32	+28V RTN
3	CELL 6+	13	TEMP ERR 3	23	TS1 RTN	33	+28V RTN
4	CELL 8+	14	TEMP ERR 4	24	TS2 RTN	34	ON HI
5	CELL 1+	15	OUTPUT RTN	25	TS3 RTN	35	OFF HI
6	CELL 3+	16	TS1	26	TS4 RTN	36	OFF LO
7	CELL 5+	17	TS2	27	PS_MON	37	ON LO
8	CELL 7+	18	TS3	28	RS232 OUT		
9	CELL RTN	19	TS4	29	+28VDC		
10	PRE CONDITION	20	HIGH CELL	30	+28VDC		

NOTE: Cell 1+ connects to the top (+) of the battery stack and CELL RTN connects to the bottom (-) of the battery stack

Standard Configuration

Power Requirement

83 mA Typ at +28VDC

Operating Temperature

0°C to +70°C

Storage Temperature

-40°C to +85°C

Ordering Information

MODEL NUMBER
BEU8642-EVAL

EXPORT CONTROL:

This product is controlled for export under the International Traffic in Arms Regulations (ITAR). A license from the U.S. Department of State is required prior to the export of this product from the United States.

EXPORT WARNING:

Aeroflex's military and space products are controlled for export under the International Traffic in Arms Regulations (ITAR) and may not be sold or proposed or offered for sale to certain countries. (See ITAR 126.1 for complete information.)

PLAINVIEW, NEW YORK

Toll Free: 800-THE-1553
Fax: 516-694-6715

INTERNATIONAL

Tel: 805-778-9229
Fax: 805-778-1980

NORTHEAST

Tel: 603-888-3975
Fax: 603-888-4585

SE AND MID-ATLANTIC

Tel: 321-951-4164
Fax: 321-951-4254

WEST COAST

Tel: 949-362-2260
Fax: 949-362-2266

CENTRAL

Tel: 719-594-8017
Fax: 719-594-8468

www.aeroflex.com info-ams@aeroflex.com

Aeroflex Microelectronic Solutions reserves the right to change at any time without notice the specifications, design, function, or form of its products described herein. All parameters must be validated for each customer's application by engineering. No liability is assumed as a result of use of this product. No patent licenses are implied.



Our passion for performance is defined by three attributes represented by these three icons: solution-minded, performance-driven and customer-focused