

MUX8520 16-Channel Analog Multiplexer Module Radiation Tolerant & ESD Protected

www.aeroflex.com/mux

April 17, 2009



FEATURES

- 16 Channels provided by one multiplexer
- Radiation performance
 - Total dose: 300 krad(Si), Dose rate = 50 - 300 rad(Si)/s
 - SEU: Immune up to 120 MeV-cm²/mg
 - SEL: Immune by process design
- Full military temperature range
- Low power consumption < 15mW
- One address bus (A0-3), and one enable line
- All channel inputs protected by ±20V nominal Transorbbs
- Fast access time 1500ns typical
- Break-Before-Make switching
- High analog input impedance (power on or off)
- Designed for aerospace and high reliability space applications
- Packaging – Hermetic ceramic
 - 56 leads, 0.80" Sq x 0.20"Ht quad flat pack
 - Typical Weight 6 grams
- DSCC SMD 5962-09229 pending

Note: Aeroflex Plainview does not currently have a DSCC certified Radiation Hardened Assurance Program.

GENERAL DESCRIPTION

Aeroflex's MUX8520 is a radiation tolerant, 16 channel multiplexer MCM (Multi Chip Module) with electrostatic discharge (ESD) protection on all channel inputs.

The MUX8520 has been specifically designed to meet exposure to radiation environments. It is available in a 56 lead High Temperature Co-Fired Ceramic (HTCC) Quad Flatpack (CQFP). It is guaranteed operational from -55°C to +125°C. Available screened in accordance with MIL-PRF-38534, the MUX8520 is ideal for demanding military and space applications.

ORGANIZATION AND APPLICATION

The MUX8520 consists of one 16 channel multiplexer arranged as shown in the block diagram, addressable by bus A₀~A₃ including enable which connects the addressed channel to a single output.

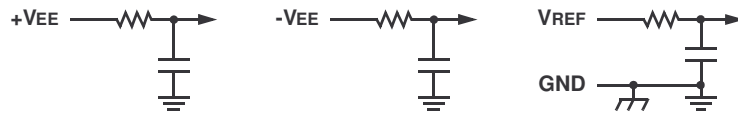
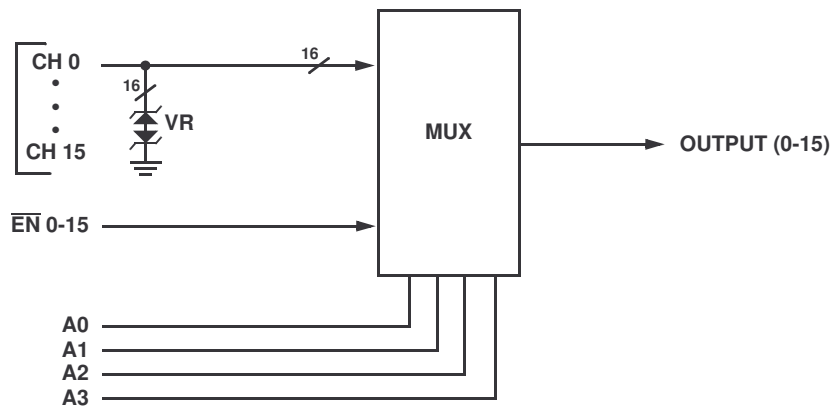

MUX8520: 16-CHANNEL ANALOG MUX BLOCK DIAGRAM

ABSOLUTE MAXIMUM RATINGS ^{1/}

Parameter	Range	Units
Case Operating Temperature Range	-55 to +125	°C
Storage Temperature Range	-65 to +150	°C
Supply Voltage +VEE (Pin 18) -VEE (Pin 46) VREF (Pin 39)	+16.5 -16.5 +16.5	V V V
Digital Input Overvoltage VEN (Pin 13), VA (Pins 14, 15, 16, 17)	< VREF +4 > GND -4	V V
Analog Input Over Voltage VS	±18V	V

Notes:

^{1/} All measurements are made with respect to ground.

NOTICE: Stresses above those listed under "Absolute Maximums Rating" may cause permanent damage to the device. These are stress rating only; functional operation beyond the "Operation Conditions" is not recommended and extended exposure beyond the "Operation Conditions" may affect device reliability.

RECOMMENDED OPERATING CONDITIONS ^{1/}

Symbol	Parameter	Typical	Units
+VEE	+15V Power Supply Voltage	+15.0	V
-VEE	-15V Power Supply Voltage	-15.0	V
VREF	Reference Voltage	+5.00	V
VAL	Logic Low Level	+0.8	V
VAH	Logic High Level	+4.0	V

^{1/} Power Supply turn-on sequence shall be as follows: +VEE, -VEE, followed by VREF.

DC ELECTRICAL PERFORMANCE CHARACTERISTICS ^{1/}

(T_C = -55°C TO +125°C, +VEE = +15V, -VEE = -15V, VREF = +5.0V -- UNLESS OTHERWISE SPECIFIED)

Parameter	Symbol	Conditions	Min	Max	Units
Supply Current	+IEE	VEN(0-15) = VA(0-3) = 0	0.05	0.5	mA
	-IEE	VEN(0-15) = VA(0-3) = 0	-0.5	-0.05	mA
	+ISBY	VEN(0-15) = 4V, VA(0-3) = 0 ^{6/}	0.05	0.5	mA
	-ISBY	VEN(0-15) = 4V, VA(0-3) = 0 ^{6/}	-0.5	-0.05	mA
Address Input Current	I _{AL} (0-3)A	VA = 0V	-1	1	μA
	I _{AH} (0-3)A	VA = 5V	-1	1	μA
Enable Input Current	I _{ENL} (0-15)	VEN(0-15) = 0V	-1	1	μA
	I _{ENH} (0-15)	VEN(0-15) = 5V	-1	1	μA

DC ELECTRICAL PERFORMANCE CHARACTERISTICS ^{1/} (continued)

(T_C = -55°C TO +125°C, +V_{EE} = +15V, -V_{EE} = -15V, V_{REF} = +5.0V -- UNLESS OTHERWISE SPECIFIED)

Parameter	Symbol	Conditions	Min	Max	Units	
Positive Input Leakage Current CH0-CH15	+ISOFFOUTPUT(ALL)	V _{IN} = +10V, V _{EN} = 4V, output and all unused MUX inputs under test = -10V ^{2/} , ^{3/}	-100	+700	nA	
Negative Input Leakage Current CH0-CH15	-ISOFFOUTPUT(ALL)	V _{IN} = -10V, V _{EN} = 4V, output and all unused MUX inputs under test = +10V ^{2/} , ^{3/}	-100	+700	nA	
Positive Output Leakage Current OUTPUTS (pin 12)	+IDOFFOUTPUT(ALL)	V _{OUT} = +10V, V _{EN} = 4V, output and all unused MUX inputs under test = -10V ^{3/} , ^{4/}	-100	+100	nA	
Negative Output Leakage Current OUTPUTS (pin 12)	-IDOFFOUTPUT(ALL)	V _{OUT} = -10V, V _{EN} = 4V, output and all unused MUX inputs under test = +10V ^{3/} , ^{4/}	-100	+100	nA	
Input Clamped Voltage CH0 - CH15	+VCLMP	V _{EN} = 4V, all unused MUX inputs under test are open. ^{3/}	+25°C	18.0	23.0	V
			+125°C	18.0	23.5	V
			-55°C	17.5	22.5	V
Input Clamped Voltage CH0 - CH15	-VCLMP		+25°C	-23.0	-18.0	V
			+125°C	-23.5	-18.0	V
			-55°C	-22.5	-17.5	V
Switch ON Resistance OUTPUTS (pin 12)	RDS(ON)(0-15) _A	V _{IN} = +15V, V _{EN} = 0.8V, I _{OUT} = -1mA ^{2/} , ^{3/} , ^{5/}	500	3000	Ω	
	RDS(ON)(0-15) _B	V _{IN} = +5V, V _{EN} = 0.8V, I _{OUT} = -1mA ^{2/} , ^{3/} , ^{5/}	500	3000	Ω	
	RDS(ON)(0-15) _C	V _{IN} = -5V, V _{EN} = 0.8V, I _{OUT} = +1mA ^{2/} , ^{3/} , ^{5/}	500	3000	Ω	

Notes:

^{1/} Measure inputs sequentially. Ground all unused inputs of the device under test. V_A is the applied input voltage to the address lines A(0-3).

^{2/} V_{IN} is the applied input voltage to the input channels CH0-CH15.

^{3/} V_{EN} is the applied input voltage to the enable line EN(0-15).

^{4/} V_{OUT} is the applied input voltage to the output line OUTPUT (0-15)

^{5/} Negative current is the current flowing out of each of the MUX pins. Positive current is the current flowing into each MUX pin.

^{6/} Not tested, guaranteed to the specified limits.

SWITCHING CHARACTERISTICS

(T_C = -55°C TO +125°C, +V_{EE} = +15V, -V_{EE} = -15V, V_{REF} = +5.0V - UNLESS OTHERWISE SPECIFIED)

Parameter	Symbol	Conditions	Min	Max	Units
Switching Test MUX	t _{AHL}	R _L = 10KΩ, C _L = 50pF	10	1500	ns
	t _{ALH}	R _L = 10KΩ, C _L = 50pF T _c = +25°C, +125°C T _c = -55°C	10	2000	ns
			10	5000	ns
	t _{ONEN}	R _L = 1KΩ, C _L = 50pF	10	1500	ns
t _{OFFEN}	10		1000	ns	

TRUTH TABLE (CH0 – CH15)

A3	A2	A1	A0	$\overline{\text{EN}}(0-15)$	"ON" CHANNEL <u>1/</u>
X	X	X	X	H	NONE
L	L	L	L	L	CH0
L	L	L	H	L	CH1
L	L	H	L	L	CH2
L	L	H	H	L	CH3
L	H	L	L	L	CH4
L	H	L	H	L	CH5
L	H	H	L	L	CH6
L	H	H	H	L	CH7
H	L	L	L	L	CH8
H	L	L	H	L	CH9
H	L	H	L	L	CH10
H	L	H	H	L	CH11
H	H	L	L	L	CH12
H	H	L	H	L	CH13
H	H	H	L	L	CH14
H	H	H	H	L	CH15

1/ Between CH0-15 and OUTPUT (0-15)

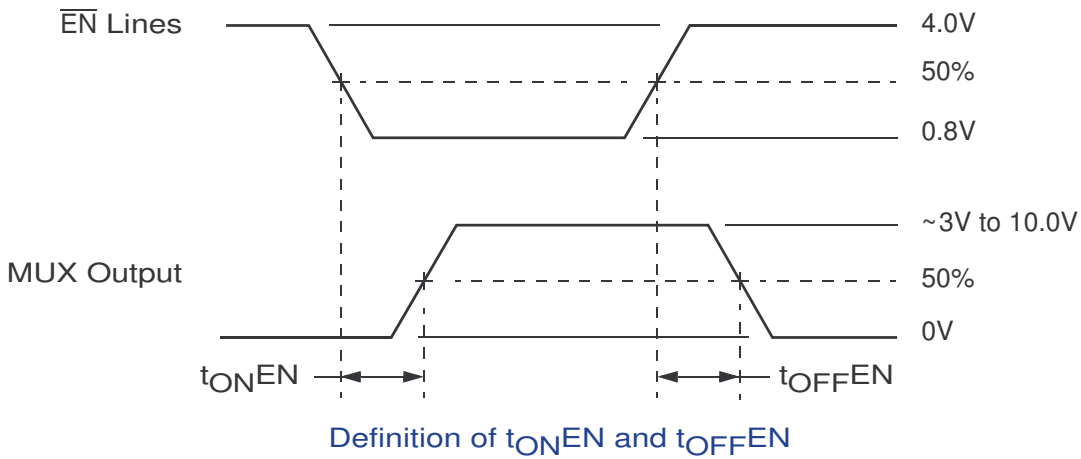
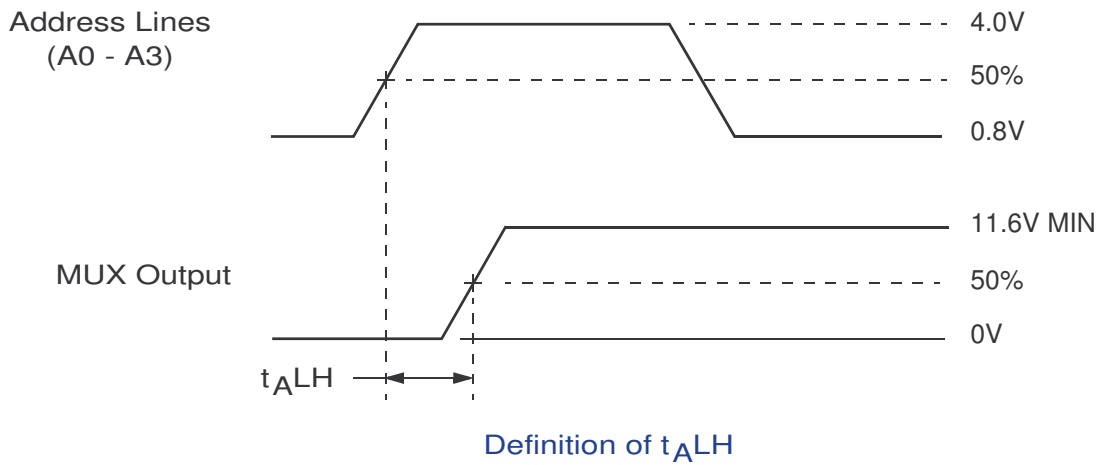
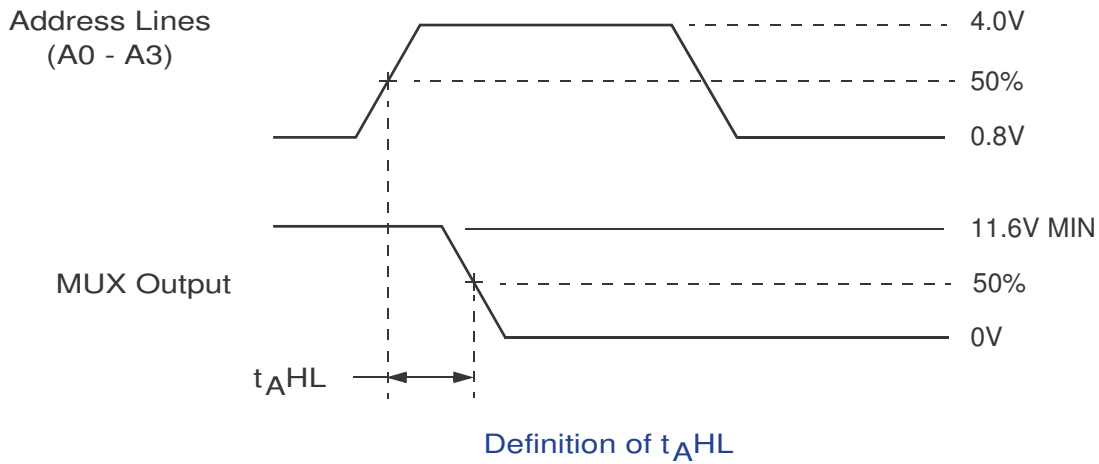

NOTE: $f = 10\text{KHz}$, Duty cycle = 50%.

MUX8520 SWITCHING DIAGRAMS

PIN NUMBERS & FUNCTIONS

MUX8520 – 56 Leads Ceramic QUAD Flat Pack			
Pin #	Function	Pin #	Function
1	CH0	29	NC
2	CH1	30	NC
3	CH2	31	NC
4	CH3	32	NC
5	CH4	33	NC
6	CH5	34	NC
7	GND	35	GND
8	GND	36	GND
9	CH6	37	NC
10	CH7	38	NC
11	CASE GND	39	VREF
12	OUTPUT (0-15)	40	NC
13	$\overline{\text{EN}}$ 0-15	41	NC
14	A0	42	NC
15	A1	43	NC
16	A2	44	NC
17	A3	45	NC
18	+VEE	46	-VEE
19	CH15	47	NC
20	CH14	48	NC
21	GND	49	GND
22	GND	50	GND
23	CH13	51	NC
24	CH12	52	NC
25	CH11	53	NC
26	CH10	54	NC
27	CH9	55	NC
28	CH8	56	NC

Notes:

1. It is recommended that all "NC" or "no connect pin", be grounded. This eliminates or minimizes any ESD or static buildup.
2. Package lid is internally connected to circuit ground (Pins 7, 8, 11, 21, 22, 35, 36, 49, 50).

ORDERING INFORMATION

Model	DSCC SMD #	Screening	Package
MUX8520-S	-	Military Temperature, -55°C to +125°C Screened in accordance with MIL-PRF-38534, Class K	QUAD Flat Pack
MUX8520-7	-	Commercial Flow, +25°C testing only	
MUX8520-201-1S	5962-0922901KXC (Pending)	In accordance with DSCC SMD	

PACKAGE OUTLINE

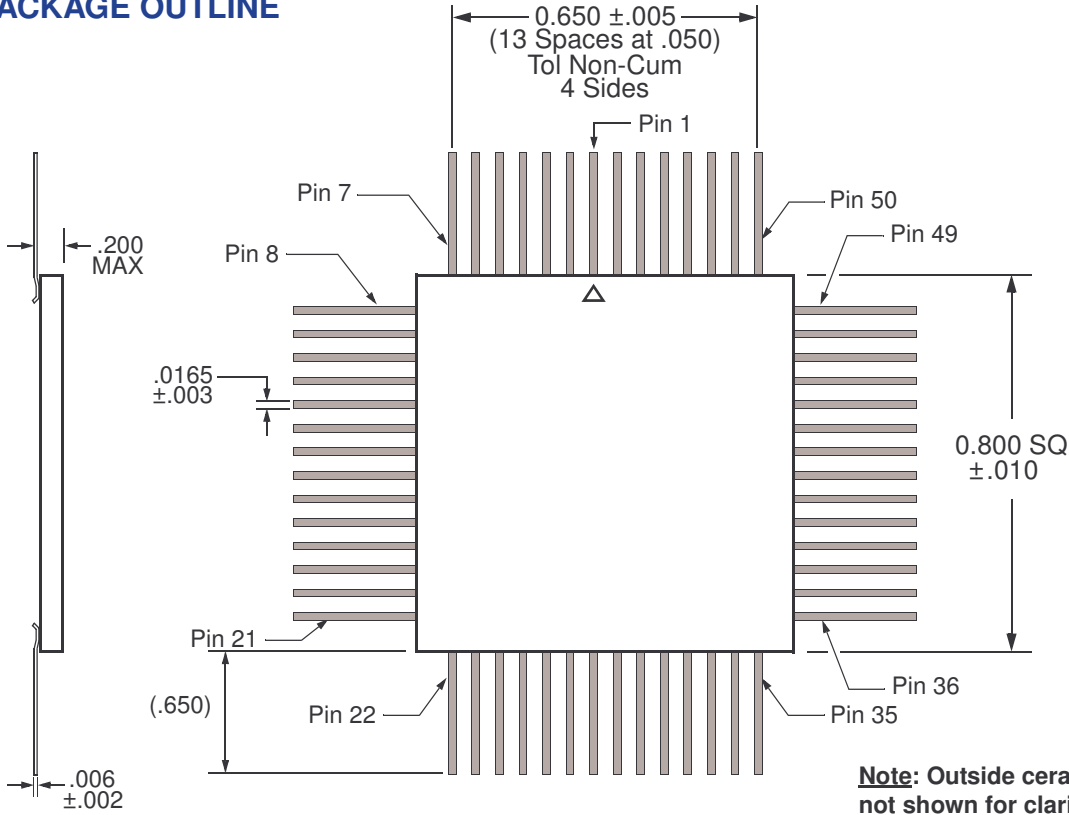

Note: Outside ceramic tie bars not shown for clarity. Contact factory for details.

EXPORT CONTROL:

This product is controlled for export under the International Traffic in Arms Regulations (ITAR). A license from the U.S. Department of State is required prior to the export of this product from the United States.

EXPORT WARNING:

Aeroflex's military and space products are controlled for export under the International Traffic in Arms Regulations (ITAR) and may not be sold or proposed or offered for sale to certain countries. (See ITAR 126.1 for complete information.)

PLAINVIEW, NEW YORK
Toll Free: 800-THE-1553
Fax: 516-694-6715

INTERNATIONAL
Tel: 805-778-9229
Fax: 805-778-1980

NORTHEAST
Tel: 603-888-3975
Fax: 603-888-4585

SE AND MID-ATLANTIC
Tel: 321-951-4164
Fax: 321-951-4254

WEST COAST
Tel: 949-362-2260
Fax: 949-362-2266

CENTRAL
Tel: 719-594-8017
Fax: 719-594-8468

www.aeroflex.com info-ams@eroflex.com

Aeroflex Microelectronic Solutions reserves the right to change at any time without notice the specifications, design, function, or form of its products described herein. All parameters must be validated for each customer's application by engineering. No liability is assumed as a result of use of this product. No patent licenses are implied.



Our passion for performance is defined by three attributes represented by these three icons: solution-minded, performance-driven and customer-focused