

Achieving cell balancing for lithium-ion batteries

Cell balancing allows the selection of a much smaller battery to achieve a desired output capacity

BY GEORGE ALTEMOSE
Aeroflex, Plainview, NY
<http://www.aeroflex.com>

Lithium-ion batteries were introduced in 1991 and have become the preferred technology for many applications, ranging from satellites to land vehicles to model airplanes, as well as laptop computers and cell phones. This is primarily due to their outstanding energy density, which is the ratio of stored energy to weight.

Voltage drop

Li-ion cells are designed to provide a voltage in the range of approximately 3.0 to 4.3 V. It is extremely important to maintain the voltage of a Li-ion cell between its design limits at all times, or the cell will be irreparably damaged. If a cell's voltage is allowed to drop below 3.0 V, the cell can go into a state of deep discharge, from which it may take hours or even days to recover.

In fact, deep discharge may cause the cell to short-circuit, an event from which it will not recover. Overcharging to a voltage greater than 4.3 V can be even worse because this can cause the cell to destruct, possibly with severe overheating or other catastrophic results. In simple applications using only a single Li-ion cell, the electronic control circuit must protect the cell by shutting off the load when the cell voltage drops below 3.2 V and limiting the voltage during charging to less than 4.2 V.

Li-ion construction

A Li-ion battery is constructed by connecting two or more cells in series. In this configuration, the battery voltage is equal to the sum of the individual cell voltages. For example, a 96-V battery is obtained by connect-

ing 24 Li-ion cells in series. When a load is applied, the load current flows out of all 24 series cells. When the battery is being charged, the charger supplies charging current to the series string of cells. In both cases, the discharging and charging currents in all the cells are equal.

Over the life of the battery, the battery may be charged and discharged for hundreds or even thousands of cycles. As this occurs, the individual cells may age differently. Some cells may become slightly (or more than slightly) mismatched with respect to the others. If this phenomenon is not corrected, one or more cells may become undercharged or overcharged, either of which can lead to failure of the battery.

Balancing

The methodology for correcting this condition is called balancing. Balancing is the process of forcing all of the cells to have identical voltages. This is accomplished by a balancing circuit.

The Aeroflex balancing circuit uses a Share bus, which has a voltage equal to the average voltage of all the cells. The balancing circuit takes charge from the cells that are above the Share bus voltage and injects the charge into the cells that are of lower voltage, using high-efficiency bilateral dc/ac converters.

The magnitude of the balancing current is proportional to the voltage difference, that is, as the cells become closer to being perfectly balanced, the balancing currents approach zero. *Figure 1* illustrates a five-cell balanc-

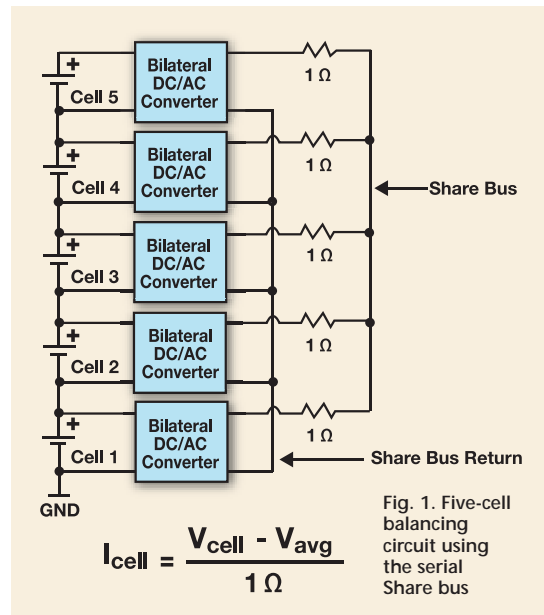

Fig. 1. Five-cell balancing circuit using the serial Share bus

ing circuit, with 1- Ω resistors setting the transfer ratio, which is the ratio of the imbalance voltage ($V_{\text{cell}}/V_{\text{avg}}$) to the balancing current (I_{cell}).

For batteries of relatively large capacity (typically 20 Ah or more), balancing currents up to 1-A are desirable in order to minimize the time to reach balance. For these applications, the bilateral dc/ac converter circuit uses planar transformers operating at a frequency of about 100 kHz.

The battery electronics unit

Each circuit is a forward converter with resonant reset, and the switching frequency is controlled by a phase-locked loop to provide precise low-loss switching and high efficiency. *Figure 2* shows a battery electronics unit (BEU) for a 24-cell Li-ion battery satellite application using this circuit topology. This BEU also features individual cell voltage monitoring, with the voltage of each cell measured with an accuracy of 10 mV, using a 12-bit A/D, and

